



**LEVERAGING SCIENCE FOR SECURITY:
A STRATEGY FOR THE NUCLEAR
WEAPONS LABORATORIES IN THE
21ST CENTURY**

**Task Force on Leveraging the Scientific and
Technological Capabilities of the NNSA National
Laboratories for 21st Century National Security**

Frances Fragos Townsend, Co-Chair
Lt. Gen. (Ret.) Donald Kerrick, Co-Chair
Elizabeth Turpen, Ph.D., Project Director

March 2009

Copyright ©2009
The Henry L. Stimson Center

Report Number 71
Cover photo by Randy Montoya.
Used with permission of Sandia National Laboratories.
Cover design by Shawn Woodley and Free Range Studios.

All rights reserved. No part of this publication may be reproduced or transmitted
in any form or by any means without prior written consent from
The Henry L. Stimson Center.

The Henry L. Stimson Center
1111 19th Street, NW 12th Floor Washington, DC 20036
telephone: 202-223-5956 fax: 202-238-9604 www.stimson.org

TABLE OF CONTENTS

Acronyms	iv
Preface.....	vi
Acknowledgments.....	vii
EXECUTIVE SUMMARY	1
CHAPTER 1: INTRODUCTION.....	9
CHAPTER 2: THE “QUIET CRISIS” IN US SCIENCE AND TECHNOLOGY	11
CHAPTER 3: INSTITUTIONAL HISTORY OF THE NUCLEAR WEAPONS ENTERPRISE	17
CHAPTER 4: VISION A 21ST CENTURY NATIONAL SECURITY ENTERPRISE	27
CHAPTER 5: TASK FORCE FINDINGS AND RECOMMENDATIONS	33
CHAPTER 6: CONCLUSION.....	51
Appendix I: Task Force Members.....	53
Appendix II: Statement of Work	58
Appendix III: General Cooperative Research and Development Agreement Guidance	61
Appendix IV: Work For Others	66
Appendix V: Expanding Opportunities and Streamlining WFO Processes	68
Endnotes.....	71
Bibliography.....	75
About the Stimson Center	80

ACRONYMS

AEC	Atomic Energy Commission
ANS	Agency for Nuclear Stewardship
ANSA	Agency for National Security Applications
B&R	Budget and Reporting
BOA	Basic Ordering Agreement
BPO	Business Process Outsourcing
BRIC	Brazil, Russia, India, and China
CPRC	Counterproliferation Program Review Committee
CRADA	Cooperative Research and Development Agreement
CTBT	Comprehensive Test Ban Treaty
CTTSO	Combating Terrorism Technology Support Office
D&D	Decommissioning and Dismantlement
DEAR	Department of Energy Acquisition Regulation
DHS	US Department of Homeland Security
DNFSB	Defense Nuclear Facilities Safety Board
DoD	US Department of Defense
DoE	US Department of Energy
DoE/IN	US Department of Energy Office of Intelligence
DSB	Defense Science Board
DTRA	Defense Threat Reduction Agency
ERDA	Energy Research and Development Administration
ES&H	Environment, Safety, and Health
FAC	Federal Administration Charge
FAR	Federal Acquisition Regulations
FFRDC	Federally Funded Research and Development Center
FY	Fiscal Year
GDP	Gross Domestic Product
GOCO	Government-Owned Contractor-Operated
IC	Intelligence Community
IDIQ	Indefinite Delivery Indefinite Quantity
IED	Improvised Explosive Device
IP	Intellectual Property
IT	Information Technology
JCAE	(Congressional) Joint Committee on Atomic Energy
LANL	Los Alamos National Laboratory
LDRD	Laboratory Directed Research and Development
LEP	Life Extension Program
LLC	Limited Liability Corporation
LLNL	Lawrence Livermore National Laboratory
M&O	Management and Operations
MIT	Massachusetts Institute of Technology

MOU	Memorandum of Understanding
NFE	Non-Federal Entities
NNSA	National Nuclear Security Administration
NRC	Nuclear Regulatory Commission
NSC	National Security Council
NSF	National Science Foundation
NTS	Nevada Test Site
OFA	Other Federal Agency
OIJP	Office of Institutional and Joint Programs (NNSA)
OMB	Office of Management and Budget
OPEC	Organization of Petroleum Exporting Countries
OS	Department of Energy Office of Science
PEP	Performance Evaluation Plan
PFIAB	President's Foreign Intelligence Advisory Board
PTS	Project Task Statement
R&D	Research and Development
S&S	Safeguards and Security
S&T	Science and Technology
SEDI	Systems Engineering and Development Institute
SNL	Sandia National Laboratories
SOW	Statement of Work
ST&E	Science, Technology, and Engineering
START I	Strategic Arms Reduction Treaty
TSWG	Technical Support Working Group
USG	United States Government
WFO	Work for Others
WWO	Work with Others

PREFACE

Dear Reader,

I am pleased to present **Leveraging Science for Security: A Strategy for the Nuclear Weapons Laboratories in the 21st Century**, the report of a Stimson Center Task Force that addresses a critical 21st century security topic: the role of the nuclear weapons Laboratories in addressing the needs of a new era. As repositories of the nation's core knowledge and innovation with respect to nuclear weapons, the NNSA Laboratories and their talent pool are also engaged in critical research and thinking about nuclear terrorism, forensics, and counter- and nonproliferation as well as other 21st century security concerns. The Task Force grappled with a wide set of issues related to the future of the Laboratories and the security requirements of the US government.

Ably co-chaired by former Assistant to President Bush for Homeland Security and Counterterrorism Frances Fragos Townsend and former Deputy National Security Advisor to President Clinton Lt. Gen. (Ret.) Donald Kerrick, the Task Force was directed by Stimson Center Senior Associate Dr. Elizabeth Turpen, who managed the process and was the principal drafter of this report. The Task Force held a series of meetings in 2008, in Washington, DC, and at the three Laboratories, meeting with diverse experts from government, industry, and academia. The report offers some bold solutions to problems of governance and leadership, attempting to find creative approaches to ensure maximum effectiveness and efficiency in using the Laboratories as national resources.

We are grateful to the Co-Chairs, Ms. Townsend and Lt. Gen. Kerrick, for their commitment to this project, and to the entire Task Force for engaging in such lively and open debate and discussion. We hope that the findings of this report will be useful to decision-makers in government who face hard choices about setting priorities in national security spending, and will also be useful to the science and technology community, in government and outside, as they work to advance science and contribute to public policy.

Sincerely,



Ellen Laipson, President/CEO
The Henry L. Stimson Center

ACKNOWLEDGMENTS

The Stimson Task Force received substantial support from the National Nuclear Security Administration (PO number VK-1006). We are exceedingly grateful to John Harvey for his help in introducing early concept papers regarding this project to key officials within NNSA and his stalwart assistance throughout various stages of this project. Also, this effort never would have taken root without support from Tom D’Agostino, NNSA Administrator, as well as George Allen and Dimitri Kusnezov. Also, many thanks to Dave Crandall for his thorough answers to the numerous budgetary, legal, and other questions the Task Force put to him. In addition, we are very grateful to Jeff Paisner and Phil Goldstone of Los Alamos, Bill Bookless and T.R. Koncher of Livermore, and Wendell Jones and David Keese of Sandia National Laboratories, among others at the NNSA Laboratories, for their support of the site visits, fulfillment of information requests, and incisive comments to early drafts of this report.

This Task Force also would not have come to fruition without the support of the Richard Lounsbery Foundation. A heartfelt thanks to Max Angerholzer, Lounsbery’s Executive Director, for his confidence in the Stimson Center’s ability to steward this endeavor to a successful conclusion. Also, we extend our deep appreciation to Bonnie Jenkins at the Ford Foundation for a generous grant focused on finalizing the report and its widespread dissemination (grant number 1095-0106).

Many thanks also to John Browne, General John Gordon, Mim John, and Bruce Tarter for volunteering their time to review and provide incisive comments on initial drafts of this report. We have done our best to reflect their views and insights to the fullest extent possible within the confines of the Task Force’s domain of consensus. Please note that some aspects of the Stimson Task Force’s findings and recommendations may not necessarily fully coincide with those of this advisory group. We also recognize the vital support provided by Brian Finlay, Alex Reed, and Aditi Haté in bringing this effort to a successful conclusion.

DISCLAIMER

The findings and recommendations contained in this report are those of the Task Force members as interpreted by the Project Director, Elizabeth Turpen, and do not represent the views of the NNSA, the Richard Lounsbery Foundation, the Ford Foundation, or the Stimson Center. Any mistakes or inaccurate interpretations of meaning or intent are the sole responsibility of the Task Force.

EXECUTIVE SUMMARY

The United States is quickly losing its leadership position in science and technology (S&T). We are seeing this in our schools, our research institutes, in the intelligence community, and in our National Laboratories.* Thus, it is imperative that a set of new and strategic grand challenges be identified and pursued to re-establish and assure the nation's global S&T leadership in the 21st century. In addition, turning the tide to address this crisis will require formidable leadership in key Cabinet and White House positions and steadfast emphasis on science as a catalyst to the economic recovery, competitiveness, and security. Most importantly, the new administration must devise a national S&T strategy that brings all of the nation's laboratories together in collaboration with industry and academe to tackle the nation's dominant challenges, particularly those pertinent to national security.

This report of the Stimson Center's Task Force on "Leveraging the Nuclear Weapons Laboratories for 21st Century Security" addresses one critical aspect of our nation's S&T future: transformation of our nuclear weapons Laboratories.** In early 2008, the Stimson Center convened a bipartisan Task Force comprised of counterterrorism, nonproliferation, intelligence, military, business, and scientific experts to provide the incoming administration with a roadmap to more effectively leverage the existing capabilities at the nation's nuclear weapons Laboratories and Nevada Test Site (NTS) to meet an array of emerging vital national security challenges. The strategy has two key purposes: to ensure retention of core nuclear weapons competencies at the weapons Laboratories and NTS, and to expand their S&T capabilities to service a wider array of 21st century national security needs.

The erosion of the nation's S&T base partly reflects the lack of clarity regarding post-Cold War security priorities and the ineptitude of existing institutional structures to adequately prioritize and allocate investments to address a rapidly changing global environment. As the US grapples with the structural changes to its national security architecture requisite to respond with greater agility to the rapidly changing international

* Declining federal investment in R&D has had a significant impact on our standing, particularly as R&D investments have contracted in the private sector as well. From 1965 to 2002, the share of federally funded R&D had dropped from 60 percent to below 30 percent of overall investments, which has negatively impacted all of our nation's laboratories. See: National Academies Committee on Prospering in the Global Economy of the 21st Century: An Agenda for American Science and Technology and Committee on Science, Engineering, and Public Policy, *Rising Above the Gathering Storm* (Washington: National Academies Press, 2007): 137.

** The US nuclear weapons Laboratories are Los Alamos National Laboratory, Lawrence Livermore National Laboratory, and Sandia National Laboratories. In this report "S&T transformation" refers to the continuing evolution of these Laboratories from their traditional mission space and nuclear weapons-specific capabilities to becoming a "21st century national security enterprise." This entails achievement of a shared investment strategy and governance structure that addresses continuing nuclear stockpile requirements while better leveraging the Laboratories' core capabilities to service government-wide S&T national security needs.

environment, it must also ensure a robust and agile S&T base to address a diffuse array of threats, including support to a changing strategic posture.

For more than 40 years, the United States has relied on the nuclear weapons Laboratories and the Nevada Test Site to provide strategic and tactical solutions to the serious threats facing our nation. Because of the materials science, physics, chemistry, and engineering issues associated with nuclear weapons, many unique capabilities that were developed for, and then sustained by, the US nuclear weapons mission have been readily available for application to a broad spectrum of national security needs. These Laboratories have responded to new national security needs by drawing upon past significant investments made in science, technology, computation, and test facilities. All of these assets were required to develop and sustain a premier nuclear weapons design, production, and certification capability to meet an evolving strategic outlook.

In past decades, the size of the nuclear weapons budget allowed for a healthy amount of high-risk, long-term research at the weapons Laboratories, much of it growing out of, but diverging from, the core weapons-related capabilities. Importantly, the diverse capabilities resident at the Laboratories have permitted other national security agencies to periodically tap into that scientific expertise on an “as needed” basis, without requiring them to make the long-term investments necessary to build and sustain the enterprise. In short, a generous nuclear weapons budget created these multidisciplinary scientific reservoirs brimming with critical capabilities that could be leveraged on the cheap.

Our nuclear arsenal and the premier scientific infrastructure that ensures its safety, reliability, and performance are entering a new and potentially destabilizing phase. This assumption is based on a confluence of events, including: (1) the change in administration, (2) a congressional commission on the US strategic posture already underway and a legislative mandate for a new posture review in 2009,[†] (3) insufficient consensus in Congress on the role of our nuclear forces, (4) lack of progress on obtaining key elements of the 2001 Posture Review’s “responsive infrastructure,” and (5) recent retirements and changes in committee leadership in Congress. Viable solutions are needed to ensure that this confluence of factors does not give rise to decisions that could degrade US security.

On the campaign trail, President Obama embraced the vision of a nuclear free world, but he made clear that until the time such a world was possible, the US would maintain a “robust deterrent.” Resolving the inherent tension in these divergent goals is no easy task. The backbone of our deterrent is the scientific base at our nuclear weapons Laboratories. In order to recruit, train, and retain young, talented scientists, our political leaders must

[†] The Congressional Commission on the Strategic Posture of the United States released its interim report on December 15, 2008. The Commission noted that support for the Stockpile Stewardship Program is at risk, despite the necessity of maintaining robust capabilities, especially should the US ratify the CTBT. See: Commission on the Strategic Posture of the United States, “Interim Report,” facilitated by the United States Institute of Peace (December 15, 2008), accessed at: http://www.usip.org/strategic_posture/sprc_interim_report.pdf.

articulate a vision for the Laboratories that translates into meaningful work – a mission that young scientists can embrace and to which they will dedicate their professional lives. Simultaneously, the work to achieve this vision should not undercut US nonproliferation goals.

The new administration also must strive to maximize the return on investment in our nation’s S&T capabilities in order to address a burgeoning menu of national security needs. The weapons Laboratories bring much capability to bear. However, these Laboratories will confront colliding agendas in their current institutional setting – a renewed focus on energy security at the Department of Energy (DoE) and the assumed crunch in the budgetary means available for the department’s traditional weapons-related work. The Stimson Task Force assessed whether these countervailing pressures were surmountable within the current institutional setting or whether the attainment of a “21st century national security S&T enterprise” necessitated an entirely different governance structure to provide an integrated national strategy and elicit shared investments. The Task Force’s key findings at three different levels of analysis and our priority recommendation are offered below.

The first level of findings is at the government-wide level: *Findings*

- *Governance is the key issue.* The Laboratories and NTS need an effective coordinating entity, one that provides strategic guidance and management direction. A new governance structure would allow the US government (USG) – including the Department of Homeland Security (DHS), Department of Defense (DoD), and the Intelligence Community (IC) in particular – to better leverage the assets available at the Labs, thus elicit their longer-term investments. In light of the Task Force’s objective of providing a comprehensive research and development (R&D) strategy, it considered different structures that would allow formulation of a USG-wide strategy and shared investment in the infrastructure that it deem necessary to sustain science and technology relevant to national security needs.
- *Sustainable support of other national security agency S&T needs can be guaranteed only if the other agencies commit to long-term strategic relationships at a “sponsor” level.* These strategic relationships should entail capital investment, annual funding commitments, and participation in the long-term strategic focus of the Laboratories. This requires creating a structure for multi-agency decision-making and investment and eliminating “primary” versus “secondary” access to the Labs’ capabilities. This “investment” will require commitment and support by the Office of Management and Budget (OMB), the agencies, and the Congress. This multi-agency support should reduce costs for all agency clients, while preserving these national resources and maximizing their service to the nation.

- *Diversification of investments requires a new governance “ethos.”* Additional funding will likely be required to make national security beyond nuclear weapons a core mission requirement at the Labs. It is appropriate that many agencies (DoD, DHS, Department of State, Department and Justice, and the IC) as well as DoE work to realize a true sense of partnership in ensuring that unique national security capabilities will be readily available when needed, rather than seeking access to these resources in a tactical and opportunistic manner. Currently, DoE is singularly responsible for maintaining, managing, and largely funding these capabilities for the benefit of other agencies. These other agencies should now also accept the responsibility to maintain and nourish the programs that foster the needed capabilities.
- *DoD currently determines required weapon capabilities while DoE has to deal with budgetary consequences of funding and maintaining the skill sets and facilities necessary to fulfill the DoD requirements.* At present, the disconnect between DoD and DoE regarding nuclear weapons production and maintenance capabilities is complicating such institutional arrangements. Full engagement of DoD is required both with respect to formulating requirements as well as in making a case for the correlative budgetary needs.¹
- *Work for Others (WFO) and strategic Memorandums of Understanding (MOUs) are likely too limited and too ad hoc to allow for the ideal long-range strategic planning for the S&T enterprise.[‡]* Strategic MOUs offer a flavor of shared investment for mutually desired outcomes, but they do not represent a binding financial investment. The National Nuclear Security Administration (NNSA) would have to arrange a large number of these MOUs tailored to each competency identified to achieve the desired effect. It is highly likely that neither WFO nor strategic MOUs can achieve the “governance” requisite to prioritize and allocate spending in a manner that ensures the appropriate long-term investments are forthcoming and most efficiently leverages the S&T base.
- *Strengthening relationships with other agencies to induce investments is critical to the long-term interests of national security.* Improved models of investment and a further reduction of barriers to investment by federal entities (especially IC, DHS, DoD) outside DoE/NNSA is necessary. Doing so will provide additional stability of funding and facilities support and enhance the Laboratories’ ability to manage and develop their capabilities.

[‡] WFO is a term the Department of Energy uses to describe Laboratory taskings from the non-DoE agencies to the laboratories. In addition to WFO, the National Nuclear Security Administration plans to negotiate long-term memorandums of understanding (MOUs) with agencies that continually use some aspect of the Laboratories’ capabilities.

The second level of findings is between NNSA and the Laboratories: *Findings*

- *The implementation of the NNSA Act failed to achieve the intended autonomy for NNSA within the Department of Energy.* The Labs now must operate within a complicated set of bureaucratic relationships with both DoE and NNSA. An excessively bureaucratic DoE culture has infiltrated NNSA as well.
- *NNSA and the Laboratories do not always work in partnership with one another.* Rather than the NNSA telling the Laboratories “what” and the Labs responding with “how,” the Labs are defining “what” and the NNSA (in particular, the site offices) is micromanaging “how.” Due to this dynamic, the Laboratories try to circumvent authority by going straight to Congress.
 - *Filtering of national Laboratory expertise and analyses through headquarters staff only serves to diminish the availability of laboratory technical analyses to serve the needs of non-DoE agencies.* As a prime example, the DoE’s Office of Intelligence (DoE/IN) is responsive to the Secretary of Energy’s intelligence needs. As a result, it intervenes in the research agendas of the Laboratories, pressing them more towards current intelligence and challenging the program plans of Laboratory managers, regardless of the desires of the non-DoE intelligence customers’ needs.
- *The Labs require greater strategic guidance from NNSA (or their primary government sponsor) without unnecessarily curtailing their management autonomy and operational flexibility.* The Laboratories need top-down coordination and political consensus in order to push their mission. Currently, imposed constraints and bureaucracy are unmanageable for Laboratory leadership. Simultaneously, the federal government has failed to define the Laboratories’ mission. (This is similar to our finding on WFO at the Laboratory level, but this refers to the NNSA-to-Laboratory dynamic.)
 - *Allocation of investments across all the Laboratories is suboptimal, which impedes strengthening of capabilities or focusing of research efforts.* This approach does not maximize a return on investment and creates expensive redundancies in programs/capabilities across the complex, hurts the quality of response, and causes unnecessary meetings/travel/coordination and other inefficiencies with no demonstrable improvement in response time or ingenuity.

- *NNSA’s vision regarding “Focus Area 4” of its S&T transformation and WFO objective is a very positive step in the right direction.*[§] In order to achieve that vision, however, the Laboratories must be able to respond to national needs quickly, efficiently, and at a reasonable cost. Onerous oversight or management of WFO program performance by Headquarters or site offices will put additional NNSA contributions to broader national security needs at risk.
- *Escalating Environmental Safety and Health (ES&H) and Safeguards and Security (S&S) standards have put a squeeze on basic research/S&T within the stewardship program.* This situation is exacerbated by the maintenance and recapitalization costs for an aging infrastructure.
- *The transition to the Limited Liability Company (LLC) model and continuous re-competes has led to tremendous anxiety at the Laboratories.* Technical staff, especially the younger cadre, expressed substantial concerns over the viability of their careers at the Laboratories in the face of uncertainties in management. In addition, DoE/NNSA compliance and process requirements increase the percentage of their time spent on administrative versus technical/scientific pursuits.

**And, lastly, the third level of analysis is at the Laboratory level:
*Findings***

- *If the decline in nuclear weapons budgets continues and other agencies’ investments cannot be secured, core competencies applicable to a range of critical national security needs will be severely eroded or lost.* Long-term investments are required from users beyond DoE/NNSA to shore up critical national security competencies.
- *The Laboratories’ research areas have expanded dramatically and their approach is sometimes bottom-up and not well coordinated as part of an integrated national strategy.* Neither NNSA nor the Labs have been disciplined in ensuring that they focus solely on challenges where they have suitable capabilities. In particular, the Laboratories appear to have evolved from multi-purpose to all-purpose. This has led to a lack of clarity regarding mission and purpose that requires the unique capabilities of the national Laboratories. Opportunism at the Laboratory level is exacerbated by a fragmented (and sometimes parochial) Congressional appropriations process.

[§] Focus Area 4 encompasses the Task Force’s main objective. This Focus speaks to the S&T underpinning the entire NNSA mission space, weapons-related and beyond, and the future possibilities of an integrated strategy to service S&T requirements across the US government.

Based on this set of key findings, the Task Force worked to delineate an appropriate strategy to achieve the desired transformation. In order to realize the vision of multi-agency leveraging of the NNSA Labs' unique S&T capabilities, the first-order decision had to address the institutional arrangements to achieve appropriate prioritization and allocation of investments.

Recommendation

The Task Force concludes that the basic choice is pretty clear:

- *Initiate an extensive overhaul of DoE/NNSA to achieve intended agency autonomy and immediate action on numerous recommendations outlined in detail in Section IV*

OR

- *Create a new independent agency with the institutional mechanisms and oversight in place to achieve the envisioned transformation and fully leverage the taxpayer's investments in the Laboratories S&T infrastructure for government-wide national security.*

After a careful weighing of the options, the Task Force strongly recommends creating a fully independent agency for national security science and technology – the Agency for National Security Applications (ANSA). The Task Force saw this as the most viable option for achievement of the S&T transformation vision and the efficacy of our national security S&T infrastructure. This action would enable the Laboratories to remain trusted third party advisors as well as providers of capabilities, but it would initiate a full transformation from a Cold War, industrial age mindset and culture to a more flexible and adaptable information age, organizational structure. In addition, the proposed organizational change would catalyze the multi-agency investment schemes and synergies necessary to fully achieve the S&T transformation vision. Recognizing that: (1) NNSA never realized the degree of autonomy intended by Congress; (2) that for the foreseeable future, DoE and its leadership will be fully fixated on addressing the current energy crisis, and (3) that shared investments can only be achieved through a governance structure that engenders strategic planning for government-wide national security S&T needs, the Task Force proposes fully severing NNSA and its Federally Funded Research and Development Centers (FFRDCs) including the NTS, from DoE to establish the proposed Agency for National Security Applications.**

** The NNSA Laboratories are Federally Funded Research and Development Centers. FFRDCs are “privately owned but government-funded entities that have long-term relationships with one or more federal agencies to perform research and development and related tasks.” See Government Accountability Office, “Federal Research: Opportunities Exist to Improve the Management and Oversight of Federally Funded Research and Development Centers,” GAO-09-15 (October 2008): 4.

INTRODUCTION

Our nation is witnessing a precipitous decline in global science and technology (S&T) leadership. The steady erosion of our worldwide innovation dominance permeates many facets of our nation's economic competitiveness, and, indeed, our national security. One specific reflection of this trend can be seen in the aging of the S&T expertise and thinning of capabilities at our nation's nuclear weapons Laboratories. A strategic set of new and grand challenges must be identified and pursued to re-establish and assure the nation's global S&T leadership in the 21st century. An important starting point in arresting and reversing this crisis will be the redeployment of the multidisciplinary competencies at our nation's nuclear weapons Laboratories to address an array of 21st century national security challenges.

The US nuclear deterrent and the scientific infrastructure that ensures its safety, reliability, and performance are entering a new and potentially destabilizing phase. This is based on a confluence of current events, including: (1) the change in administration, (2) a congressional commission on the US strategic posture already underway and a legislative mandate for a new posture review in 2009, (3) insufficient consensus in Congress on the role of our nuclear forces, (4) lack of progress on obtaining key elements of 2001 Posture Review's "responsive infrastructure," and (5) recent retirements and changes in committee leadership in Congress. This constellation of factors has the potential to give rise to decisions that would be detrimental to our nation's nuclear weapons Laboratories and our national security.

In past decades, the size of the nuclear weapons budget allowed for a healthy amount of high risk, long-term, and basic research at the weapons Laboratories – much of it growing out of, but diverging from the core weapons-related capabilities. Importantly, the diverse capabilities resident at these Laboratories permitted other national security agencies to tap into that scientific expertise on an "as needed" basis without making the long-term investments necessary to build and sustain it. In short, a generous nuclear weapons budget created these robust, multidisciplinary Laboratories brimming with critical capabilities that could be leveraged on the cheap. These capabilities, particularly in the past couple of years, have begun to erode. A major adjustment in governance and budgetary sources for the Laboratories will be required to avoid further erosion of our national S&T base and core nuclear weapons capabilities.

In order to provide a strategy to address the challenges confronting our nuclear weapons Laboratories, in early 2008 the Stimson Center convened a bipartisan Task Force comprised of counterterrorism, nonproliferation, intelligence, business, and scientific experts to provide the incoming administration with a roadmap to more effectively

leverage the existing capabilities at the nation's nuclear weapons Laboratories and Nevada Test Site (NTS) to meet an array of emerging vital national security challenges. The strategy's objective is two-fold: to ensure retention of core nuclear weapons competencies at the weapons Laboratories and NTS, while better leveraging their S&T capabilities to service an array of 21st century national security needs.

The report encompasses seven chapters. Chapter 2 briefly addresses the erosion of our nation's S&T leadership and the nuclear weapons Laboratories as a reflection of and potential starting point to reverse the decline. In Chapter 3, as context for the Task Force's findings and recommendations, the report offers a brief overview of the institutional history and current organizational challenges confronting the nuclear weapons Laboratories and NTS. A detailed explanation of the vision encapsulated by such a "21st Century National Security Enterprise" for the nuclear weapons complex is offered in Chapter 4. Chapter 5 outlines the Task Force's key findings and recommendations, as well as the proposed new governance structure to achieve the Task Force's vision. The Task Force's conclusions can be found in Chapter 6.

THE “QUIET CRISIS” IN US SCIENCE AND TECHNOLOGY

Among the dominant challenges confronting the nation in the 21st century is the decline of the United States’ leadership role in science and technology – termed a “quiet crisis” by journalist and commentator Thomas Friedman. In the past few years, the United States has been slipping precipitously from its long-dominant position in an increasingly global and competitive S&T enterprise. Countries like China and India have made significant gains in technology innovation and in attracting high-technology and e-commerce opportunities. These governments are making substantial investments to build up their technical education systems and attract talent to their countries. In addition, they have focused heavily on their national research and development (R&D) infrastructures by paying special attention to harvesting their domestic S&T knowledge and talent base within research institutes and universities and by prioritizing their respective engineering, manufacturing, and Information Technology (IT) industries.²

The rise in global S&T competence sharply contrasts with the accelerating – and parallel – decline of the United States’ comparative advantage in knowledge discovery and innovation. Although according to all indices, the US still maintains the strongest innovation system in the world, that lead is expected to shrink dramatically by 2015, particularly when compared to the developing economies of China and India. Both governments have prioritized the enhancement of their R&D capabilities and have gone to great lengths to establish comprehensive, government-sponsored supportive frameworks. Indeed, by 2015, this component – at just 70% of what is considered optimal for any country – will be the weakest link in the US innovation system.³ Similarly, in the area of human capital, the US is expected to witness the erosion of its pre-eminence. A recent government-commissioned study predicts a mere 2% improvement US S&T talent, with China and India benefiting from a rise of 19% and 15% respectively.⁴ Such trends extend beyond the BRIC (Brazil, Russia, India, and China) economies to include many countries in the developing world.*

* The Global Innovation Index 2008, published jointly by the French INSEAD Business School and the Confederation of Indian Industry notes that while knowledge creation, competitiveness, and wealth creation continues to be dominated by the United States, those same leading indicators suggest an emerging capacity across the developing world both within but also well beyond the BRIC economies. In the Middle East, the United Arab Emirates, Qatar and Kuwait are noted for the emergence of technology clusters and human capital development. Slovakia, Slovenia, Estonia and the Czech Republic all ranked above India as emerging leaders in the knowledge economy. Emerging East Asian economies have registered dramatic increases in the rate of growth of international patenting. Another study of national innovative capacity ranks Costa Rica, Trinidad and Tobago, Panama, Thailand, Mauritius, Egypt, Uruguay, Malaysia, the Dominican Republic, and an array of developing countries on its innovative capacity index. See: BW Online Bureau, “India Not Among Top Innovators,” *Businessworld* (January 6, 2009), accessed at: <http://www.businessworld.in/index.php/B->

The demographic dimension within the US is equally disconcerting. The National Science Foundation (NSF) underscored this creeping crisis in its 2006 estimation that about one-half of America's scientists and engineers are 40 years of age or older and that this average age is steadily rising. One prominent example of this reality is an analysis of NASA personnel from 2004 showing that only 4% of its 18,146 employees were under the age of 30, while nearly 40% were 50 years or older.⁵ Directly pertinent to the S&T competencies under the Task Force's purview, the Chiles Commission on Nuclear Expertise expressed growing concern in its 1999 report about the aging DoE weapons complex workforce. At that time, 34% of the employees supplying critical skills to the weapons program were more than 50 years old—a population considerably older than that for the average US high-technology industry.⁶ Today, that number has increased to 40% of the DoE laboratories' essential workers. The three weapons Laboratories reported in late 2008 that they employ 6,908 personnel with "essential skills." Of these employees, only 24.6% are below 40 years of age, an age group that the Defense Science Board (DSB) deems to be "substantially under-represented." In comparison, approximately 36% of the US national science and engineering workforce is below the age of 40 years.⁷

To compound these trends, a considerable portion of the United States' in-house, high-tech capabilities is being shipped overseas. Not only have the large, corporate R&D laboratories reduced their commitment to high-risk, long-term research in favor of short-term R&D work, but in recent years, they have begun to redirect their high-technology R&D activities and facilities to developing countries that provide not only a cheaper means of production (specifically lower labor costs), but also confer lower corporate tax rates, special government incentives, and intellectual property protection laws. All of these measures combine to result in markedly higher profit margins for the companies. Also, in many cases, such outsourcing generates a robust foreign R&D talent pool (scientists, engineers, programmers, and technicians) that can take on these activities as competitively as their American counterparts.⁸ For instance, Western information technology and finance companies now routinely conduct their back-office operations (such as technical support functions or payment collection) out of hundreds of Indian "business process outsourcing" (BPO) centers, more commonly known as call centers, that are managed and staffed by low-cost, English-speaking Indian graduates with engineering, science, and other technical degrees.⁹ Similarly, many US companies coordinate complex supply chains and workflows for their manufacturing industries out of China. Other competitors are catching up quickly to this outsourcing trend as countries like Japan, South Korea, Taiwan, and even some European counterparts, including Ireland and Finland, are actively pursuing opportunities to attract and absorb similar investment and innovation activities.¹⁰

School/India-Not-Among-Top-Innovators.html; Soumitra Dutta, "Technological Innovation in the Middle East," INSEAD, accessed at: <http://knowledge.insead.edu/contents/Soumitra.cfm>.

These trends in the private sector reflect a similar pattern in US federal S&T investments. Since the end of the Cold War, the relative budget devoted to science has continued to decline. For example, federal funding of research in the physical sciences, as a percentage of Gross Domestic Product (GDP), was 45% less in fiscal year (FY) 2004 than in FY 1976. The amount invested annually by the US government into research in the physical sciences, mathematics, and engineering *combined* is equal to the annual increase in US healthcare costs incurred every six weeks.¹¹ Moreover, federal budgets for national security R&D experienced a significant and steady decline during the 1990s and only started a recovery in the years following September 11, 2001. In order to reverse this decline, a 2004 industry-academic Task Force on the Future of American Innovation argued that an increase of 10% to 12% each year for at least five to seven years would be required in the budgets of key research-funding agencies such as: the National Institute for Science and Technology, the NSF, the DoE's Office of Science (OS), and the DoD research accounts.¹²

This quiet crisis has not gone unnoticed by authors, experts and, most notably, the 2007 National Academies' report, *Rising Above the Gathering Storm*. Yet the US government has been slow to respond. The Obama administration will confront a substantial challenge in arresting and reversing this situation in light of other more immediate and visible crises. In order to adequately address this quiet crisis, the new administration should devise a national S&T strategy that brings all of the nation's laboratories together in a legitimate consortium with industry and academe to tackle the nation's dominant scientific challenges. Actions are already underway on the issues of energy and climate change, but a much more expansive vision is warranted. The assessment and corresponding strategy should address the overall S&T challenge, as well as evaluate the requirements for a responsive, agile S&T base to more effectively respond to the full array of current and emerging national security challenges. *Such a comprehensive strategy would likely help inform the mission set and further delineate which of the non-National Nuclear Security Administration Federally Funded Research and Development Centers (FFRDCs) might appropriately reside under the fully autonomous agency proposed by the Stimson Task Force, as described on page 44.*

CONTRIBUTION OF DOE NATIONAL LABS TO NATIONAL SECURITY SCIENCE AND TECHNOLOGY

Although the overall S&T outlook is critical to US competitiveness and the country's broad national security interests, the Stimson Task Force was charged with addressing only a subset of the broader challenge, namely, a strategy for transforming the NNSA Laboratories^{§*} to attain a "21st Century S&T enterprise" responsive to US national security needs. (See Appendix II for the Task Force's Statement of Work.) While the Task Force's fact-finding efforts focused on the nuclear weapons Laboratories, several non-NNSA DoE laboratories also make significant S&T contributions in support of the

^{§*} Hereinafter, any reference to the national laboratories, including other DoE laboratories, is not capitalized; all references to the NNSA Laboratories will be capitalized.

country's national security needs and objectives. The OS is responsible for oversight of some of these laboratories, including: Argonne National Laboratory, Brookhaven National Laboratory, Oak Ridge National Laboratory, and Pacific Northwest National Laboratory. Idaho National Laboratory also contributes to S&T activities for national security, but it is housed within the Office of Nuclear Energy.¹³

The NNSA Laboratories include the three main nuclear weapons Laboratories: Lawrence Livermore National Laboratory (LLNL), Los Alamos National Laboratory (LANL), and Sandia National Laboratories (SNL). While stewardship of the US nuclear arsenal will remain a core mission of the NNSA Laboratories for the foreseeable future, these Laboratories also have long provided critical S&T capabilities to serve many national security agencies within the US government. In addition, as part of NNSA's oversight responsibility and as a key component of the nuclear weapons R&D complex, the Task Force incorporated the NTS into its fact-finding and overall assessment. According to information supplied by the NNSA Laboratories, the percentage of their budgets dedicated to defense programs (nuclear weapons) in fiscal year 2008 ranged from 43% at Sandia to 60% at Lawrence Livermore. The NNSA Laboratories also receive funding to fulfill R&D requirements from the Intelligence Community (IC), the Department of Homeland Security (DHS), the Pentagon, interagency agreements, and funding documents. Because of their traditional mission space and corresponding dependence on Defense Program funding, the NNSA Laboratories fill a particular niche within the US Laboratory system and maintain unique capabilities and facilities.

The three NNSA Laboratories and the OS laboratories all contribute their resources and S&T capabilities to the broader international and domestic activities of the United States government (USG). In addition, these labs are involved in R&D processes to innovate new technologies to help address emerging national security threats. These labs have contributed extensively to the IC and Department of Defense (DoD) programs on a variety of national security issues including, but not limited to, nuclear nonproliferation, safeguards and security, weapons of mass destruction threat reduction, radiation materials detection, counterterrorism, critical infrastructure protection, defense systems and technologies, as well as treaty compliance and export control support.¹⁴ In addition, as per the Homeland Security Act, DHS has the equal authority like DoE to request technical and scientific assistance from the laboratories to address specific DHS S&T needs. DoE laboratories can also compete for R&D funding from the DHS S&T directorate.¹⁵ The budgetary contributions from the non-DoE agencies are substantial. As of FY2007, the IC contributed about \$544 million to DoE/NNSA facilities; DoD more than matched this contribution with \$624 million in the same year.¹⁶ The DHS directorate allocated \$103.8 million in FY 2008 for S&T funding and has requested \$147 million in the current fiscal year.¹⁷ The DoE received \$9.903 billion for R&D in FY2008 for national security, science, and energy, out of which \$3.199 billion is specifically allocated for national security.¹⁸

As the test range component of the nuclear weapons complex, the Nevada Test Site (NTS) is a unique national resource for advancing our national security S&T needs. NTS is the only place where one can conduct large-scale experiments using special nuclear materials, test open-air explosives after FY 2009, and release certain classes of toxic materials.[†] One very specific and highly relevant legacy of the weapons program is the longstanding ability of NTS to coordinate and conduct large-scale, multifaceted tests with extensive specialized diagnostics involving personnel from the relevant Laboratories. This is a critical asset and necessary proving-ground for training the next generation in the planning and implementation of large, non-iterative tests with uncertain outcomes. This competency is of interest to the IC, DoD, DHS, and potentially, other national security missions when specific experiments or tests must be conducted to validate or confirm conclusions carrying high risk, but having potentially high reward. The NTS also is performing significant work for the IC and on Improvised Explosive Devices (IEDs). In FY 2008 alone, NTS performed \$93 million in services for non-DoE customers.

The Task Force finds that the NNSA Laboratories and NTS are unique, high-value national assets. Although the NNSA Laboratories have long operated as broad national security institutions, their S&T capabilities are not being leveraged to the maximum extent possible. This is due to myriad factors, not the least of which is the lack of a national comprehensive strategy on S&T that is appropriate to the existing environment and the existence of governance structures that would allow for multi-agency prioritization of S&T requirements and corresponding long-term investments. The Task Force fully concurs with the National Academies' study that noted, "if properly managed and adequately funded, the large multidisciplinary DoE laboratories could assist in filling the "void" left when large corporate R&D laboratories decreased investments in high-risk, long-term research and began off-shoring their R&D."¹⁹ Of course, this would require extensive redeployment of the "significant national investments in personnel, shared facilities, and knowledge" at the DoE laboratories to provide solutions to vital national challenges.²⁰ Maximizing the taxpayers' return on their S&T investment, while taking the first step to arrest and reverse the quiet crisis, requires the delineation of appropriate institutional parameters to achieve these multiple objectives.

[†] The Test Site's status as the only location for open-air explosive testing after 2009 is contingent on action with respect to the Preferred Alternative in the final SPEIS, see: National Nuclear Security Administration, Final Complex Transformation Supplemental Programmatic Environmental Impact Statement: Summary (Washington: US Department of Energy, 2008): 73-74.

INSTITUTIONAL HISTORY OF THE NUCLEAR WEAPONS ENTERPRISE

As background to the integrated strategic governance and planning structure proposed by the Stimson Task Force, a brief history of the institutional arrangements for US nuclear weapons research and development is important. Obviously, the Task Force's assessment is not a blank sheet exercise and answers to questions regarding the appropriate institutional structure for the US nuclear weapons complex have never been easy. The following overview discusses the creation and dissolution of the Atomic Energy Commission, the international and domestic pressures that led to the formation of the Department of Energy, and the convergence of factors that gave rise to establishment of the National Nuclear Security Administration. This historical perspective, in conjunction with assessments of continued DoE/NNSA stewardship of the complex, are of substantial import in the Task Force's weighing of options to achieve the S&T transformation vision.

ADVENT OF THE ATOMIC AGE AND CREATION OF THE AEC

Close on the heels of President Roosevelt's 1942 authorization of the US Army Corps of Engineers to establish the Manhattan Engineering District for R&D efforts related to atomic weaponry, the Manhattan Project, as it came to be known, took over the majority of fission research with the single purpose of building an atomic bomb.²¹ After approximately three years and \$2.2 billion (\$26.7 billion in 2008 dollars), the Manhattan Project accomplished its goal with the successful Trinity test in Alamogordo, New Mexico.²² Following the bombing of Hiroshima and Nagasaki and the end of World War II, the US entered a period of intense debate regarding the future uses and control of nuclear energy – particularly the appropriate institutional framework for overseeing its dual uses.

Initial legislation regarding institutional oversight caused many scientists and civilian-control advocates to fear that the military would gain *de facto* control and shut out the civilian establishment.* This undermined President Truman's initial support for the proposed plan.† In response to this concern, Brien McMahon (D-CT) proposed a new bill

* This bill was introduced following the recommendations of the Interim Committee (the advisory group formed to determine the future and uses of atomic research. Byron S. Miller, "A Law is Passed—The Atomic Energy Act of 1946," *The University of Chicago Law Review* Vol. 15, No. 4 (Summer 1948), accessed through JSTOR.

† Those in favor of civilian control argued that military control within the Manhattan Project had led to torturous bureaucracy and delays in research and development. Moreover, the military's authoritarian training and discipline" might not be responsive enough to the public's will. Miller, "A Law is Passed," 817-818. Christopher M. Davis, "9/11 Commission Recommendations: Joint Committee on Atomic Energy — A Model

with control granted to a five-member civilian commission with “strict control over the production of fissionable material and the fabrication and stockpiling of weapons.”²³ After intense debate, the bill, with some revisions, was passed as *The Atomic Energy Act of 1946*. The act included the creation of the Atomic Energy Commission (AEC) to conduct research into military applications of nuclear technology and the President was given explicit authority over decisions of production and delivery of weapons to the military for defense purposes.²⁴

The Atomic Energy Act also created the Congressional Joint Committee on Atomic Energy (JCAE), which for 30 years oversaw the Atomic Energy Commission’s activities and general nuclear power issues. The 18-member (nine from each house) JCAE had unprecedented powers to address the assumed extraordinary challenge facing the nation.²⁵ Such powers included exclusive jurisdiction over all nuclear issues, standing legislative authority, and access to restricted data.²⁶ The combined legislative and oversight functions of the JCAE, “essentially preempted all other congressional committees except the Committee on Appropriations, from having any say whatever over the items in the JCAE’s jurisdiction.”²⁷ Authorization to remain fully abreast of AEC activities and to “utilize the services, information, facilities and personnel” of the AEC stretched the JCAE’s power further and greatly restricted the AEC’s independence.²⁸ Following the 1974 dissolution of the AEC and substantial concerns over the ties of the JCAE to the nuclear industry, Congress abolished the Joint Committee in 1977.²⁹

FROM THE ATOMIC ENERGY COMMISSION TO THE DEPARTMENT OF ENERGY

The 1970s brought considerable changes to the US government’s nuclear infrastructure, largely resulting from several energy crises. In retaliation for US support of Israel against Egypt in late 1973, the Arab members of the Organization of Petroleum Exporting Countries (OPEC) cut production and banned exports of oil to the US.³⁰ During the embargo, the price per barrel of oil quadrupled, creating urgency for research into alternative energy.³¹ This circumstance eventually led to the creation of the DoE as a full, Cabinet-level department.³² The objective of creating this new department, according to the President’s Foreign Intelligence Advisory Board, was to “take the diverse and dispersed energy research centers of the nation, bring them under an umbrella organization with other energy-related enterprises, and spark their scientific progress through closer contacts and centralized management.”³³ Unfortunately, this proposed organizational solution gave rise to a new problem: the divided attention of the Secretary of Energy and his management team in addressing energy needs, nuclear weapons, basic research, and national security issues within one department. The end of the Cold War exacerbated this challenge even more.

for Congressional Oversight?” CRS Report for Congress, RL32538, (August 20, 2004), accessed at: <http://www.fas.org/irp/crs/RL32538.pdf>.

Figure 1³⁴

Birth by Fusion: The Department of Energy

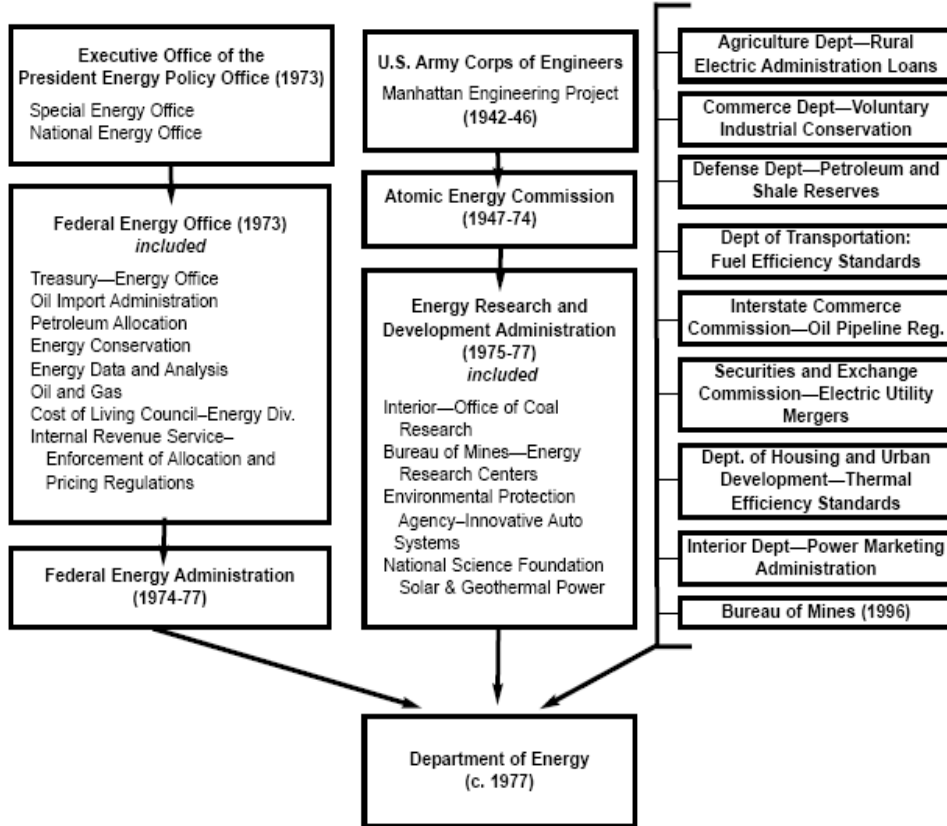

The end of the Cold War brought significant change and uncertainty to US security policies, especially the role of our nuclear arsenal. With the loss of the overt Soviet nuclear threat, nuclear weapons and deterrence quickly lost status in the security arena to other issues that previously had been considered to be of lesser concern, such as ethnic/internal conflicts, human rights, democratization, terrorism, and WMD proliferation.³⁵ Arms control agreements, such as the Strategic Arms Reduction Treaty (START I) and the Comprehensive Test Ban Treaty (CTBT), combined with the US nuclear testing moratorium enacted in 1992, further pushed nuclear weapons to the backburner of security policy, forcing DoE and the weapons complex to adapt to the new environment. Rather than the “design, test and deploy” paradigm of the Cold War era, the nuclear weapons complex took on stewardship of an aging nuclear arsenal.

With Congress’ passage of the 1994 Defense Authorization Act, the Stockpile Stewardship Program was initiated as a means to maintain the safety, reliability, and performance of the US deterrent capability and to maintain a rigorous scientific enterprise under a test moratorium.³⁶ The three weapons Laboratories conduct a range of tests on

the various components of US nuclear weapons to help ensure reliability without full-scale nuclear testing in conjunction with life extension programs (LEP) that refurbish warhead components. In addition, a large scientific enterprise of theory, modeling, simulation, and scientific experiments form the basis of understanding and assessing the stockpile. At the same time, the DoE has also added new emphasis to non-deterrence missions that include energy security, fissile material disposition, environmental remediation, and nonproliferation.³⁷ This continued expansion and diversification of Laboratory activities, together with the growing range of security challenges and larger ratio of non-DoE/NNSA funding, has further complicated the Laboratories' mission and elicited questions regarding shared investments. The DoE and NNSA have yet to fully reorient the Laboratories to the post-Cold War environment, but any attempt to do so runs headlong into the limitations of DoE's mission space vis-à-vis the full spectrum of 21st century national security challenges and the jurisdiction of multiple US agencies in addressing them. Although NNSA's most recent Strategic Planning Guidance provides a far-reaching and appropriate vision regarding S&T transformation, the fulfillment of this vision hinges on achievement of the necessary institutional arrangements to provide a cohesive, government-wide national security S&T strategy.³⁸

PRE-NNSA ASSESSMENTS OF THE INSTITUTIONAL ARRANGEMENTS (1995 - 1999)

In the latter half of the 1990s, numerous commissions, task forces, and expert panels analyzed the institutional and mission-related questions confronting the DoE Laboratories in the post-Cold War environment. These groups included the Secretary of Energy Advisory Board, which in 1995 released the report of the Task Force on Alternative Futures for the DoE National Laboratories ("The Galvin Report"). That Task Force analyzed the various roles that the Laboratories could play in areas such as national security, energy, the economy, and environmental clean-up, as well as the governance and organizational structure of the Labs and the DoE. The Task Force recognized a number of institutional problems, including: organizational compartmentalization; a lack of structure both within and across the Laboratory system, complex and redundant regulations with burdensome compliance requirements, and "micro-management of research by DoE program officers."³⁹

Four years later in March 1999, the Commission on Maintaining United States Nuclear Weapons Expertise (known as the "Chiles Commission") released its report. The Commission assessed DoE's efforts to attract and retain scientists, engineers, and technicians to staff the nuclear weapons complex, as well as the relationship between the weapons complex and the Department as a whole. Like the Galvin Report, the Chiles Commission report sharply criticized DoE and the conditions under which the Labs were operating. Uncertainty among Laboratory staff created an image of nuclear weapons as a "sunset" industry that did not receive its due in terms of both attention and support from the Department.⁴⁰ The Chiles report echoed concerns about DoE micromanagement of the Labs, the lack of clear lines of authority, and safety and health regulations creating poor morale among Laboratory employees.⁴¹ Furthermore, the Commission found "a

perceived, and often real, disconnect between DoE and DoD understanding of program needs,” exemplifying the divide between the customer and the producer.⁴²

THE CREATION OF A SEMI-AUTONOMOUS NNSA

Security lapses and repeated reports of mismanagement culminated in a “perfect storm” regarding the institutional setting for our nuclear weapons enterprise in the late 1990s. The initial report of the Panel to Assess the Reliability, Safety, and Security of the United States Nuclear Stockpile (known as the “Foster Panel”) was released in 1999 and reiterated the criticism made by previous panels regarding the need to reform DoE’s internal management practices, paying particular attention to the Department’s failure to integrate “functional responsibilities, including safety and security,” into line management.⁴³ In addition, the controversy regarding alleged Chinese espionage and security at the Laboratories reached its zenith with the release of the *Report of the Select Committee on US National Security and Military/Commercial Concerns with the People’s Republic of China* (commonly called the Cox Report after Committee Chairman Chris Cox), and the subsequent case involving Taiwanese-American physicist Dr. Wen Ho Lee.⁴⁴

Soon after the release of the Cox Report and following the first allegations made against Dr. Lee, a Special Investigative Panel of the President’s Foreign Intelligence Advisory Board (PFIAB) released its assessment of DoE’s security and counterintelligence policies. The Panel’s harshly worded report blasted the Department for “the worst security record on secrecy that the members of this panel (had) ever encountered.”⁴⁵ Citing numerous previous reports on the Department’s failings, the Panel criticized DoE’s excessive, entrenched bureaucracy; its lack of accountability; the poor relationship between DoE headquarters and the Laboratories; the consistently short tenures of Secretaries of Energy; and a Laboratory culture that was “thoroughly saturated with cynicism and disregard for authority.”⁴⁶ The report recommended separating the Labs, production facilities, and NTS from DoE, organizing them either as an independent agency or as a semi-autonomous component of the DoE.⁴⁷ As the panel noted, however, full blame did not accrue solely to DoE, stating: “Each time that the nation’s leadership has made a major change in the Department’s priorities or added another mission, it has placed additional pressure on a government agency already struggling to preserve and expand one of its most challenging historical roles: guarantor of the safety, security, and reliability of the nation’s nuclear weapons.”⁴⁸

The Wen Ho Lee case created enough political momentum for Congress to enact the most significant recommendations put forward by the PFIAB Panel. The major organizational recommendation of the Panel was the creation of the Agency for Nuclear Stewardship (ANS), which the Panel envisioned as “more mission-focused and bureaucratically streamlined than its antecedent, and devoted principally to nuclear weapons and national security matters.”⁴⁹ The Panel wrote that the ANS, “could remain an element of DoE but become semi-autonomous—by that we mean strictly segregated from the rest of the department. Alternatively, the agency could be completely independent, with its

administrator reporting directly to the President.”⁵⁰ Several Members of Congress, long waiting for an opportunity to reform DoE, jumped on the Panel’s recommendations and with President Clinton’s signing of the *National Defense Authorization Act for Fiscal Year 2000*, the semi-autonomous NNSA as created on October 5, 1999.

Most Congressional leaders who were concerned about nuclear issues argued vociferously in favor of this reform. Representative Ellen Tauscher (D-CA), whose district includes LLNL, claimed, “The rationale for ‘semi-autonomy’ was to insulate the new agency from a culture within DoE that had undermined security and management in the weapons complex, but also to preserve for the Secretary of Energy ultimate authority for policy.”⁵¹ Representative Mac Thornberry (R-TX) argued that the “NNSA will have two traits missing from DoE for the last 20 years—accountability and a clear mission.”⁵² Senator Pete Domenici (R-NM), one of the chief drafters of the reform provisions, told Congress, “We had no other way to accomplish something very important with reference to a DoE that was found to be totally dysfunctional.”⁵³ The ultimate legislation carved out several significant missions for NNSA across a broad spectrum of security issues:

- (1) To enhance US national security through the military application of nuclear energy;
- (2) To maintain and enhance the safety, reliability, and performance of the US nuclear weapons stockpile, including the ability to design, produce, and test, in order to meet national security requirements;
- (3) To provide the US Navy with safe and militarily effective nuclear propulsion plants and to ensure the safe, reliable operation of those plants;
- (4) To promote international nuclear safety and nonproliferation;
- (5) To reduce global danger from weapons of mass destruction; and,
- (6) To support US leadership in S&T.⁵⁴

Despite the political momentum behind and the legal authorities put forward in the NNSA Act, its implementation faced significant hurdles. Following the legislation’s passage, the Foster Panel released its second annual report, which cited the “serious challenges” inherited by NNSA, “impending disaster” within the production complex, and “increasing frustrations” within the weapons Laboratories.⁵⁵ The Foster Panel continued to criticize the encroachment of functional guidelines on weapons work, arguing that NNSA “should not focus on the details of task execution,” but on achieving the mission’s big picture goals.⁵⁶ In addition, the findings of a panel spearheaded by John Hamre, President and Chief Executive Officer of the Center for Strategic and International Studies, noted that the “policies and practices at DoE risked the undermining of both science and security” at the Laboratories.⁵⁷

The following year, the third Foster Panel report found NNSA to have fallen short in achieving the Congressional mandate and meeting the Panel’s own recommendations. The NNSA’s failure to get out from underneath the crushing DoE bureaucracy led to new organizational impediments, greater frustration within the Laboratories, and a culture of

complacency.⁵⁸ Showing increasing aggravation with the failure of DoE to reform, the panel wrote, “If NNSA cannot within the current year achieve the autonomy and provide the leadership Congress intended, it is appropriate for Congress to revisit other options for managing the nuclear weapons program.”⁵⁹ Two years later, the Foster Panel concluded that, despite improvements, “longstanding weaknesses in NNSA’s internal program and resource management practices continue to hamper the program.”⁶⁰

While NNSA has continued to make strides in fixing the nuclear bureaucracy, problems remain. In 2005, Senator Domenici declared, “there’s no question that what we considered to be the things that NNSA should do—how they should do it, what management scheme they should set up, the kind of personnel slots they should fill—in our opinion are far less than the law expected.”⁶¹ Two years later, the Strategic Forces Subcommittee of the House Armed Services Committee held hearings on the implementation of the NNSA Act. Chairwoman Ellen Tauscher expressed her concern, noting that, “seven years after the NNSA was created we still face many of the same problems that drove us to create the organization in the first place.”⁶² The bureaucratic obstacles that NNSA was created to overcome were still preventing the efficient operation of the weapons Laboratories in particular and the nuclear complex in general. Tauscher blamed these failures on DoE’s refusal to allow NNSA the autonomy intended by Congress.⁶³

Recent reports by the DSB reinforce the conclusion that the existing institutional configuration of the nuclear complex is facing potentially insurmountable problems. The DSB’s 2006 report on nuclear capabilities looked specifically at the US nuclear complex and DoE’s plans to transform it to better meet security needs in the 21st century. The report concluded, “The current organization, management, and programs do not provide for a nuclear weapons enterprise capable of meeting the nation’s future needs.”⁶⁴ While commenting on the deterioration of the production complex, the report also noted “the decline in scientific and engineering talent.”⁶⁵ It echoed previous criticism of DoE/NNSA in pointing to opaque lines of authority and a “culture of excessive oversight, micromanagement, and risk aversion without regard to productivity.”⁶⁶ The DSB also noted the difficult budget situation, calling on the Pentagon to “participate fully in the trade-offs, accepting prudent risks in the current environment, to help ensure a viable set of capabilities in the longer term.”⁶⁷

In May 2008, the DSB released an additional report on “Nuclear Deterrence Expertise.” Although this report looked at expertise beyond the National Laboratories and NNSA, the DSB’s overarching observations, findings, and recommendations specific to the Laboratories served as an appropriate point of departure for the Task Force’s analysis. Notably, the DSB Task Force assessed deterrence expertise (intelligence, strategy and policy, weapons effects, nuclear detection, etc.) across the Defense and Energy Departments, as well as FFRDCs and private industry, and found it notably “thin.”⁶⁸ The DSB Task Force concluded that: (1) future deterrence challenges remain highly uncertain; (2) leadership and focus on strategy, policy, programs, and operations are

badly needed; (3) skills are neither robust nor sustainable without real work; and (4) workforce aging and attrition continues to further reduce competencies. Importantly, the DSB's strategic planning recommendations included the objective of maintaining nuclear skills by managing their application in related non-nuclear (weapons) applications, where necessary (or feasible), and strategically managing nuclear skills personnel such that they can move from one part of the enterprise to another during their career. This notion directly parallels NNSA's most recent Strategic Planning Guidance and the vision set forth under Focus Area 4 of S&T transformation.[‡]

Case Study – Limitations of the Current Structure⁶⁹

Sandia – California's recent experience regarding a WFO opportunity for the Department of Homeland Security (DHS) provides a poignant example of how difficult achievement of the S&T transformation will be within the existing institutional setting. DHS currently sponsors two FFRDCs: the Homeland Security Institute and the National Biodefense Analysis and Countermeasures Center. In 2008, DHS decided to establish a third FFRDC, the Systems Engineering and Development Institute (SEDI). SEDI will be managed under the S&T Directorate but service the whole Department in providing technical expertise and systems engineering support for large-scale acquisition programs. In the Request for Proposal for SEDI, DHS expressed a desire for a prime contractor with a strong team of subcontractors due to the diverse array of capabilities required.

Sandia proposed being a named team member in a SEDI bid with MITRE as the prime. The team involved other named subcontractors, including several DoD FFRDCs. (If explicitly named in the contract, the bidder not only gets credit for the subcontractors' participation, but it also allows the subcontractor to work on any project under the contract.) This prospect was deemed synergistic with existing core competencies at Sandia and had strong support from NNSA program leadership and there were no legal barriers identified. Despite the potential positive long-term strategic advantages and low risk of this one-year contract, the Sandia request to be a named partner was denied by NNSA headquarters because it was perceived as posing too high of a risk to the existing contract model.

The need to achieve consensus across several silos, lack of a framework for the national Laboratories to support other national security agencies, and an unwillingness to assume new risks can undermine even the most appropriate work-for-other opportunities. In addition, this results in DHS having to establish separate FFRDCs that duplicate existing capabilities at significant cost to US taxpayers.

The implied current role of the DoE as an institutional umbrella – along with the demise of the Atomic Energy Commission and the 1970s energy crisis – underscores the rather haphazard evolution of the complex's current status. During the Cold War, the mission imperatives helped to keep the bureaucrats at bay and mitigated against risk averse

[‡] Strategic Planning Guidance put forward a four pillar strategy. While pillar 4 on S&T Transformation is specific to the nuclear weapons and stockpile stewardship S&T requirements, Focus Area 4 focuses specifically on the non-traditional, i.e. non-nuclear weapons, S&T transformation objectives at the NNSA Laboratories. See: NNSA, NNSA Strategic Planning Guidance for FY 2010 – FY 2014, 16.

behavior. This is no longer the case. The numerous studies that have been done since the mid-1990s indicate the difficulties confronted by the nuclear weapons enterprise within the DoE. Recognizing this reality, Congress legislated the creation of the “semi-autonomous National Nuclear Security Agency” in 2000 to address security concerns and rationalize oversight of the nuclear weapons complex. Given that NNSA never attained the autonomy intended by Congress, however, the Laboratories now function under a complicated set of DoE and NNSA regulations, guidelines, and oversight.

In addition to the findings summarized previously with respect to poor management and excessive bureaucracy, other aspects of the existing political and policy environment must be considered. The Obama administration is expected to place heavy emphasis on nonproliferation and additional nuclear arms reductions, necessitating enhanced monitoring and verification capabilities. However, with the new attention to climate change and energy security, the current Secretary of Energy will be hard-pressed to provide the needed focus on the nuclear weapons and other national security missions within his Department. In addition, the synergies achievable in the energy security domain cannot sustain the full panoply of core capabilities needed for the foreseeable future. In brief, the Task Force believes that the persistent lack of attention to the nuclear weapons mission within the Department of Energy, a renewed and acute energy crisis, burgeoning non-energy national security science and technology needs, and an uncertain outlook for the nuclear weapons budget—all raise serious questions regarding the retention of essential capabilities within the complex in the immediate future.

VISION
A 21ST CENTURY NATIONAL SECURITY
ENTERPRISE

The articulation of a broader and far-reaching vision for the NNSA National Security Laboratories is critical to the challenge of retaining the premier scientific capabilities residing at these facilities. The US must act to retain these capabilities regardless of the size of our nuclear arsenal or the trajectory of our nuclear weapons policy. Indeed, as the arsenal shrinks, the question is not about the types of capabilities, but rather the potential redundancies in these capabilities throughout the complex. The Laboratories' mission should directly derive from the urgent task of addressing the most serious national security challenges being confronted by the United States today and their alignment with the unique competencies emanating from the traditional mission served by the Laboratories. Conversely, such an alignment should not only create synergistic activities, but the investments on the non-weapons side could help to ensure retention of these unique capabilities. The strong S&T base formed through the substantial historical investments made in the US nuclear deterrent has yielded national security gains in other areas as well. Maximizing the synergies between ongoing WFO at the Laboratories and the retention of core nuclear weapons competencies requires a comprehensive look at the ongoing non-nuclear weapons work, its application to current challenges, and its nexus with the Laboratories' traditional mission. This vision also requires the attainment of both sustained and long-term investments from multiple government agencies in the unique "dual-use" national security capabilities at the Laboratories. Most importantly, a clear vision and political commitment to such investments is critical to both the recruitment and retention of the premier scientific talent needed to meet the country's unprecedented national security S&T needs in a new century.

ACHIEVING CONSENSUS AND CATALYZING TRANSFORMATION

In 2006, NNSA unveiled a plan to establish a smaller, more efficient nuclear weapons complex that could respond to new and emerging security challenges. Although differing in several key ways, this plan was broadly based on the earlier study of the Secretary of Energy Advisory Board, "Nuclear Weapons Complex of the Future." Unfortunately, neither of these plans systematically assesses the potential application of the immense scientific and engineering talent housed at the National Security Laboratories to meeting current and future national security challenges; and, none of the existing public studies evaluates, in a comprehensive manner, the potential leveraging of the ongoing non-Defense programs activities and WFO portfolio at the Laboratories toward the

development of an integrated, synergistic R&D strategy for addressing national security needs.

The implementation of a strategy that is so narrowly focused on the nuclear weapons mission would risk the loss of expert knowledge and capabilities that could be applied to solving urgent national security problems. The design of a coherent, far-reaching R&D strategy that supports both our national security and our nation's world-class scientists is an urgent priority. Such a strategy will help to ensure that S&T capabilities are not eviscerated in the process of reducing the nuclear weapons "footprint." Conversely, it could also help to ensure the retention of core competencies at the national laboratories, while better leveraging their scientific and technological capabilities to meet an array of 21st century national security needs. Lastly, such a strategy would constitute a critical first step in arresting and reversing the "quiet crisis" in our nation's global S&T leadership.

RETAINING CORE COMPETENCIES

Nuclear weapons competence – often obliquely referred to as "core competence" of the nuclear weapons laboratories – remains a national security necessity. Whether or not one believes that nuclear disarmament is desirable or feasible, a strong cadre of nuclear weapons scientists and engineers is required well into the foreseeable future as a hedge against strategic surprise as well as to ensure, at a minimum, the safety and reliability of the existing stockpile. In the past, the core competencies of the US nuclear weapons program have provided a set of capabilities that have been applied to national security challenges going far beyond the design, engineering and development of nuclear weapons. For example, the skills developed under the weapons program have been applied to the areas of nonproliferation, threat reduction, and nuclear counterterrorism, including stabilization, safety assurance, and assessment of terrorist nuclear devices, and especially nuclear forensics. These capabilities are used to inform intelligence assessments about foreign nuclear programs and to develop technologies and systems that facilitate nuclear material detection and address broader problems in intelligence collection. Many of these skills have also been applied to problems confronted by the Pentagon, most recently with IEDs, where the Laboratories and the NTS have performed critical roles. Unfortunately, maintaining such competence has become an increasingly difficult task for a variety of political and other reasons. As indicated by the DSB study cited above, a key concern for the immediate future is that the core nuclear weapons program does not provide the necessary opportunities for exercising critical competencies and keeping them honed. In addition, the US is not recruiting and training the next generation of talent in these core areas.

Case Study – Defense Program Contractions that Could Impact Other Agencies

Plutonium Exchange Program

The Nuclear Weapons Program has historically supported the plutonium exchange program – a formal program to compare the ability of the national laboratories and the U.K. Atomic Weapons Establishment to generate detailed chemical analyses of plutonium samples. The round-robin process involves splitting samples for measurement of identical materials at the participating laboratories (examining metal isotopics and trace constituents), and comparing results to determine the precision and accuracy of analytical capabilities at each laboratory. Although the scope of the effort had been defined by the needs associated with weapon component manufacturing and certification (measuring trace elements important to the metallurgy and behavior of relatively pure materials), the round-robin evaluation served as the primary means of demonstrating the quality programs of the participating laboratories, given the lack of certified reference materials for these matrices. As a consequence, a number of program areas that depend on defensible, quality analyses of nuclear materials have benefited from this activity. Due to increasing budget pressures, the weapons program cannot continue to fund the full scope of the exchange. The Laboratories are working with other agencies to secure funding for the continuation of the exchange program, supporting both weapons certification and other national security efforts (such as nuclear material safeguards and nuclear forensics) and forestalling any erosion of national capabilities.

The ability to retain core competencies at the nation’s nuclear weapons Laboratories has reached another critical juncture in the last couple of years. While the Stockpile Stewardship Program has helped to shore up existing expertise and provide incentives for fairly reliable recruitment and retention of new talent since the end of the Cold War, a variety of political and atmospheric dynamics suggest that business as usual is not an option. This is not hyperbole, but is evidenced by the outcome of successive congressional decisions – under both Republican and Democratic leadership – on some of the key objectives of the 2001 Nuclear Posture Review. In brief, the subsequent proposed actions of the NNSA to create a “responsive infrastructure” were met with only partial success in certain instances and severe skepticism on some particularly important fronts. In short, the Obama administration will need to quickly define its own variation of a “responsive” R&D infrastructure and garner bipartisan commitment to achieving this vision. Moreover, this vision must encompass a mission of meaningful and rewarding work to help foster the steady recruitment and retention of young talent to achieve its fulfillment.

RESPONSIVE INFRASTRUCTURE

The attainment of a “responsive infrastructure” is now broadly conceived as part of the objective first envisioned under “transformation” of the nuclear complex. The repeated refrain of current NNSA Administrator Thomas D’Agostino is that “maintaining the status quo is no longer acceptable.” Indeed, it will simply not be feasible. In line with this reality, the transformation objectives encompass more than just attaining a “smaller, efficient, safer, more secure and more responsive complex at the forefront of science and technology” in that NNSA’s 2008 Strategic Planning Guidance explicitly acknowledges a

projection of flat funding and a risk that trade-offs will undercut achievement of these objectives.⁷⁰

A responsive national security enterprise must meet the needs of an unknown future while still addressing existing stockpile requirements. This requires a leveraging of the investments that have been made in the Stockpile Stewardship Program aimed at enhancing the responsiveness of the design, certification, and production components of the program. The vision of the transformation set forth in NNSA's 2008 Strategic Planning Guidance consists of four pillars as outlined below:

- (1) Downsize and modernize the nuclear stockpile through the Stockpile Stewardship Program in partnership with DoD;
- (2) Attain a cost-effective national security S&T enterprise that ensures retention of needed capabilities;
- (3) Create an integrated, interdependent S&T infrastructure that employs best business practices to maximize efficiency and minimize costs; and,
- (4) Sustain the S&T base that ensures the reliability and safety of our nuclear deterrent and remains essential for long-term national security.⁷¹

Although the terminology and priority-ranking of these may differ in the new administration, especially with respect to "modernizing" the stockpile, a comprehensive overhaul of the R&D infrastructure based on the integration of these four strategies will be required to support almost any conceivable outcome of a nuclear posture review. While the Task Force's core objective focused on pillar four – advancement of the science and technology base – this objective is essentially interrelated with the first three pillars. Only by advancing the S&T base can we ensure the veracity of stockpile stewardship; this requires transforming the infrastructure and necessitates a venture that incorporates best business practices and maximizes efficiencies and costs. Fortunately, it is also this reorientation of mission space by the NNSA laboratories that will help elicit strong bipartisan consensus and support for transformation.

The nation's future deterrent capability should not adhere to a Cold War model based solely on numbers of weapons, but rather rely on the capability and capacity of our science and technology base to respond to any unforeseen strategic challenge. Achieving coherent transformation to a different deterrent posture will require more strategic leveraging of scientific and technical knowledge to support other national security missions, such as non-proliferation, nuclear counter-terrorism, nuclear forensics, and providing solutions to the intelligence community. Indeed, one could argue that one objective of the upcoming "posture review" should be to provide a vision for a responsive S&T infrastructure and needed capabilities that extend well beyond our nuclear deterrent.

Currently, the path available for achieving this vision relies on three potential mechanisms – Strategic Agreements or MOUs, WFO, and industry partnerships. NNSA's current leadership has undertaken the formulation of "strategic agreements"

with other agencies to secure long-term stable investments for addressing mutual needs. Modeled loosely on the highly successful Joint Munitions Program, these agreements would seek to leverage other agencies' resources to achieve mutually beneficial research objectives. The first iteration of such an agreement focuses on a five-year agreement between NNSA and the Defense Threat Reduction Agency.* This approach to shared investment in the long-term capabilities at the NNSA Laboratories is the most viable in achieving the strategic vision encapsulated by Focus Area 4 and should be encouraged. While this approach may achieve some of the desired shared investments, numerous arrangements would be required to shore up the various facets of core capabilities. In addition, because such arrangements are contingent on joint investments to meet shared needs between two agencies, this approach likely cannot attain effective prioritization and allocation of resources or greatest return on the taxpayers' investment across the multiple areas of the US scientific enterprise.

The WFO activities have long leveraged the exceptional scientific expertise at the NNSA Labs and been a source of additional resources.† More recently, NNSA and the Laboratories have been promoting the WWO strategy. These activities comprise an important component of the ongoing R&D activities at all three Laboratories. (See Appendix IV for description of WFO and WWO.) However, WFO neither provides the stability of long-term investments nor recapitalization or maintenance of the infrastructure at the laboratories. Also, whether as a result of either non-DoE agency "pull" for a specific capability or Laboratory "push" to capture synergistic activities outside DoE funding streams, the WFO approach likely does not fully leverage the S&T expertise or maximize the taxpayer's return on the investment.

The Laboratories' work with industry is the third component of ongoing activities that could contribute to the transformation vision and the Stimson Task Force spent extensive time in analyzing the potential opportunities in this domain as well. The findings and recommendations are outlined in the following section.

* On December 17, 2008, the National Nuclear Security Administration (NNSA) and the Defense Threat Reduction Agency (DTRA) announced finalization of an agreement "to conduct research and development on a range of shared nuclear security challenges, such as the effects of a potential detonation of a terrorist crude nuclear device." See National Nuclear Security Administration, "NNSA Partners with DTRA on Key Nuclear Security Challenges" (December 17, 2008), accessed at: <http://nnsa.energy.gov/news/2254.htm>.

† Work for Others (WFO) includes "the performance of work for non-Department of Energy (DOE) entities by DOE/NNSA personnel and/or their respective contractor personnel or the use of DOE/NNSA facilities for work that is not directly funded by DOE/NNSA appropriations."

TASK FORCE FINDINGS AND RECOMMENDATIONS

CURRENT STATE OF THE ENTERPRISE

For more than 40 years, the USG has relied on the nuclear weapons design laboratories and the NTS to provide strategic and tactical solutions to major threats to this country. Because of the materials science, physics, chemistry, and engineering issues associated with nuclear weapons, many unique capabilities that were developed for, and then sustained by, the US nuclear weapons mission were readily available for application to a broad spectrum of national security needs. These Laboratories have been mostly responsive to new national security needs by drawing upon past significant investments made in science, technology, computation, and test facilities. All of these assets were required to develop and sustain a premier nuclear weapons design, production, certification capability to meet an evolving strategic outlook. With the end of Cold War, the US has not achieved a post-Cold War corollary – a resilient S&T base responsive to a diffuse and much-less tangible threat. More than just ensuring the S&T base for security needs, defining this corollary and building the political consensus to support it would likely go a long way in stemming the “quiet crisis.”

These Laboratories are an invaluable national asset and constitute a unique suite of capabilities that must be maintained because of: 1) the mix of talented scientists and engineers within a spectrum of specialized technical disciplines; 2) their experience with nuclear weapons and materials; 3) the research, test, and computational facilities available; and 4) the fact that the scientists have clearances at the highest levels in the government. The combination of these four assets allows for the realization of never-before envisioned solutions to unanticipated threats. This also is exemplified by the fact that many existing WFO customers value the ability to tap into highly diversified science and engineering organizations that are capable of conducting work in an environment appropriate for highly sensitive national security projects. This applies both to the security necessary for classified research and business practices compatible with DoD or intelligence community requirements.

The Task Force recognizes that some facets of the above elements already exist in industry, academia, or even other national laboratories. But, the above combination in the current NNSA structure has resulted in a more mission-oriented, solution-delivery attitude, which is critical to national security. The sites operated by NNSA are unique in the DoE because they all have a role in providing a deliverable, quantified solution to meet specific characteristics and metrics. This is a defining and substantive difference from the rest of the DoE that does research for general knowledge and increased

understanding, but no specific responsibility for application, efficiency, viability, or implementation of the research results.

Today, other than Sandia National Laboratories, the weapons design Laboratories and NTS are predominantly funded by the nuclear weapons program. But, the work for other national security agencies being performed at Los Alamos, Lawrence Livermore, Sandia and NTS continues to grow and is uniformly substantially larger than the non-weapons DoE work being conducted at each of these sites. Thus, even as DoE continues to be the responsible “steward” of these Laboratories/sites, the preponderance of their research is being done on behalf of national security challenges and is being driven by non-DoE agencies. The role of nuclear weapons as a necessary element of the nation’s deterrent and national security posture will continue, but has been and will likely be diminished in the future. Thus, the question is: “What is the optimal architecture to ‘sponsor, finance, and steward’ these national security-relevant technical capabilities and facilities at these laboratories to address future government-wide needs?” This is of particular importance if the priority of nuclear weapons financed investment is reduced (possibly substantially) in the balance of this nation’s national security priorities.

KEY FINDINGS AND RECOMMENDATIONS

The Task Force concluded that governance was the key issue. The Laboratories and Nevada Test Site need more federal leadership and less federal management to be effective and efficient. **Therefore, realizing the vision put forward in the Strategic Planning Guidance regarding a 21st century S&T enterprise requires the creation of a new agency with a multi-agency governance structure for strategic planning, setting priorities and ensuring appropriate investments in the above mentioned national security Laboratories and the NTS will be realized.**

Four sections below outline the Task Force’s findings and recommendations that led to this conclusion: 1) the Laboratories and their relationship to non-DoE/NNSA agencies and industry, 2) the relationship between the Laboratories and DoE/NNSA, and 3) the relationship of the DoE/NNSA to other national security agencies. The chapter concludes with a discussion of the scope and charter of the new Agency and the government-wide national security S&T and organizational requirements requisite to sustain a superior ability to respond to future national security threats quickly and effectively.

The findings and recommendations start from the bottom-up so as to ensure that findings/recommendations pertinent to the existing organizations or a successor agency get documented in their entirety.

Laboratory Interface with Other US Government Agencies and with Private Industry

Mission and Core Competencies

General Findings

- *If the decline in nuclear weapons budgets continues and other agencies' investments cannot be secured, core competencies applicable to a range of critical national security needs will be severely eroded or lost. Long-term investments are required from users beyond DoE/NNSA to shore up critical national security competencies.*
- *The Laboratories' research areas have expanded dramatically and their approach is sometimes bottom-up and not well coordinated as part of an integrated national strategy. Neither NNSA nor the Labs have been disciplined in ensuring that they focus solely on challenges where they have suitable capabilities. In particular, the Laboratories appear to have evolved from multi-purpose to all-purpose. This has led to lack of clarity regarding mission and purpose that requires the unique capabilities of the National Laboratories. Opportunism at the Laboratory level is exacerbated by a fragmented (and sometimes parochial) Congressional appropriations process.*

Recommendations

- *Create multi-agency sponsorship of the weapons Labs and NTS to ensure that the S&T capabilities, originally developed by the nuclear weapons program and now being leveraged to support other agencies' missions, will continue to be nurtured regardless of the level of the nuclear weapons budget. If this recommendation is not taken, explore alternative means to achieve strategic planning and long-term investments by other national security agencies. (See below)*
 - *Conduct critical internal (Laboratory) and external (outside the new agency) review, strategic prioritization and oversight to address mission growth/creep and redundancy. This will ensure the best science & engineering work is done to address and support the most significant national security challenges. While Laboratory Directed Research and Development (LDRD) funding will remain at the sole discretion of the Laboratories, a broader government-wide examination should ensure that the LDRD supports enduring requirements according to clear, transparent guidelines rooted in an integrated national strategy.*
 - *Formulate an investment plan, prioritized and agreed to by the Government Agency customers, to recapitalize the S&T infrastructure.*

This will require striking an appropriate balance between sustaining and modernizing the S&T versus the production infrastructure – a point of significant tension.

Work For Others and Memorandums of Understanding *Findings*

- *The Labs' current WFO programming is frequently tactical and a result of serendipity (i.e. personal relationships), but typically not a result of a strategic vision promulgated by NNSA or a strategic relationship for the non-DoE customer that will elicit long-term investments to sustain the infrastructure.** These Laboratories will not survive, much less thrive, if dominated by short-turnaround, piecemeal tasks. Without a clear strategy that delineates the mission(s) and baseline capabilities and provides corresponding ensured long-term investments, the pressure to be “all things to all (potential) consumers” may undermine core capabilities.
- *WFO funding has helped keep indirect rates stable and has assisted or (in certain cases) solely maintained some critical skill sets; a major challenge in establishing an enduring WFO portfolio is the application of a viable and reasonable cost model.* Full cost recovery is required (including legacy responsibilities in some cases), but is not applied uniformly across the laboratories and can be deemed cost prohibitive for most non-nuclear-weapons customers.†

Recommendations

- *Conduct an internal and external review (as mentioned in prior section) that includes standard criteria for decision making on WFO opportunities.* Such criteria should be based on the principle of adjacency.‡ NNSA with the Laboratories should establish a long-term strategy (over a period of five or more years) that provides guidance regarding appropriate research portfolio for WFO activities at each of the Laboratories; activities should be subject only to an

* The Strategic Defense Initiative under General James Abrahamson is one notable exception to this finding. How the Laboratories were leveraged under this initiative might also offer insights regarding potential solutions to this problem.

† According to DoE Order 522.1, full cost recovery includes all direct and indirect costs of conducting a project other than depreciation and imputed interest. DoE also adds an additional 3 percent general administrative charge. See: Department of Energy, “Pricing of Departmental Materials and Services,” DOE O 522.1 (November 3, 2004), accessed at: <http://www.directives.doe.gov/pdfs/doe/doetext/neword/522/05221.pdf>.

‡ Strategies for successful growth focus foremost on identifying one or two well-defined, dominant “cores” within a business and then finding adjacent opportunities that move away from but are related to and can, in turn, enhance the core. Otherwise healthy companies have failed completely by moving into a “hot” business arena, but one that ultimately led to them abandoning or eroding their core. See Chris Zook, *Beyond the Core: Expand Your Market Without Abandoning Your Roots* (Boston: Harvard Business School Press, 2004).

annual review by NNSA to ensure that they are consistent with NNSA guidance and consistent with that strategy.

- *Establish a single umbrella Basic Ordering Agreement contract between non-DoE agencies and the NNSA Laboratories and NTS.* The agreement would address all generic intellectual property (IP), cost, compliance, general contracting and liability issues with multi-year provisions. Once signed, the non-DoE agency can go to any of the weapons design labs or NTS to negotiate the actual cost and schedule for the specific task as a Task Order without further Site Office or NNSA approval.

Industry Partnerships

Findings

- *Businesses who know how to navigate the bureaucracy and culture find the Labs' expertise in certain areas unparalleled (including, inter alia, engineering, materials science, physics and optics).*
- *The Laboratories do not have a well-defined protocol for partnering (meaning as a team member) with industry.* Whereas industry generally comes to the Laboratories to get a problem solved, it is by teaming with industry to achieve a mutual objective that a capability will be nurtured or sustained. Done effectively, this is also a powerful tool to transfer capability to industry, which strengthens the broader responsiveness of the US to national security needs. One routine method of partnering is through a Commercial Research and Development Agreement (CRADA).[§] (See Appendix III for our findings/recommendations on CRADAs and an overview of the advantages and disadvantages they confer to the parties.)
- *The Laboratories sometimes do not sufficiently understand and protect exclusivity rights – limiting the exclusivity to a very specific area, while allowing other use of the technology in a related, but different, manner.* This causes significant problems for industry collaboration.
- *The National Laboratories cost an average of two to three times more than private industry.* High cost and certainty of increasing costs as well as additional DoE regulations is a barrier to other national security customers forming strategic relationships and making long-term financial investments in the DoE laboratories and the NTS.

§ A CRADA fosters joint work between the industrial partner and the DoE Laboratory allowing for Laboratory-based inventions to be commercialized; the CRADA specifies how the IP that has been generated prior to the CRADA and during the CRADA is to be protected and usually the commercial partner can enjoy the benefits of the CRADA results with a few exceptions detailed below.

Recommendations

- *Laboratories must create a different interface with industry* – one that facilitates technology transfer and injects additional business know-how into the Lab. Labs should consider creation of an outside industry review or advisory panel to devise workable options. An additional idea is presented below as part of the proposed organizational restructuring in section 4.**
 - NNSA should established specific domains where the Laboratories can partner/team with industry to address national security needs.

- *Laboratories should establish a review process* that assesses whether specific projects/technologies are closely associated with the core weapons mission and have usefulness only in the core weapons mission. *If the technology or method has wider applicability, it likely should be a candidate for commercialization.*

Internal DoE/NNSA and Laboratory Interface

Findings

- *The implementation of the NNSA Act failed to achieve the intended autonomy for that Agency within DoE.* The Labs now must operate within a complicated set of bureaucratic relationships with both DoE and NNSA. An excessively bureaucratic DoE culture has infiltrated NNSA as well.

Figure 2: A Simplified Version of DoE Governance

The following flow chart represents a simplified oversight and decision tree for NNSA Laboratories, NTS, and the production plants. Acronyms key is as follows: FARs (Federal Acquisition Regulations); DNFSB (Defense Nuclear Facilities Safety Board); DEARs (Department of Energy Acquisition Regulations); LLC (Limited Liability Corporation); M&O (Management and Operations); PEP (Performance Evaluation Plan).

** The Laboratories had industrial advisory boards in the 1990s. It would be important to cull the lessons learned regarding this earlier effort to infuse the Laboratories with business expertise via such a board.

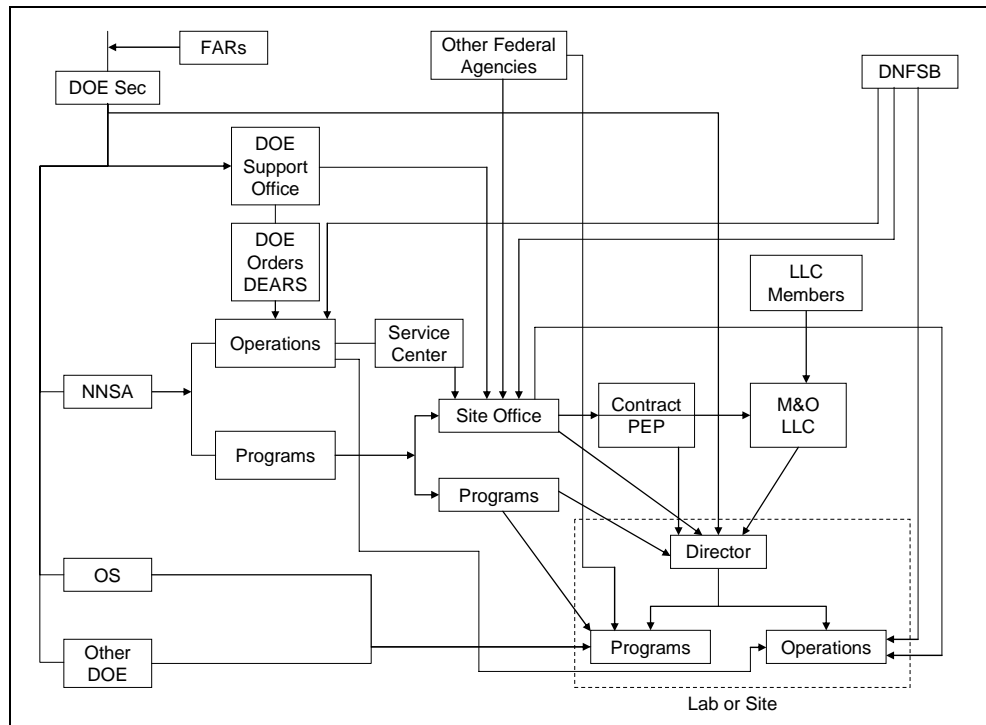

- *NNSA and the Laboratories do not always work in partnership with one another.* Rather than the NNSA telling the Laboratories “what” and the Labs responding with “how,” the Labs are defining “what” and the NNSA (in particular, the site offices) is micromanaging “how.” Due to this dynamic, the Laboratories try to circumvent authority by going straight to Congress.
 - *Filtering of national Laboratory expertise and analyses through headquarters staff only serves to diminish the availability of laboratory technical analyses to serve the needs of non-DoE agencies.* As a prime example, DoE/IN is responsive to the Secretary of Energy’s intelligence needs. As a result, it intervenes in the research agendas of the laboratories, pressing them more towards current intelligence and challenging the program plans of laboratory managers, regardless of the desires of the non-DoE intelligence customers’ needs.
- *The Labs require greater strategic guidance from NNSA (or an alternative agency) without unnecessarily curtailing their management autonomy and operational flexibility.* The Laboratories need top-down coordination and political consensus in order to push their mission. Currently, imposed constraints and bureaucracy are unmanageable for Laboratory leadership. Simultaneously, the federal government has failed to define the Laboratories’ mission. (This is

similar to our finding on WFO at the Laboratory level, but this refers to the NNSA-to-Laboratory dynamic.)

- *Allocation of investments across all the Laboratories is suboptimal, which impedes strengthening of capabilities or focusing of research efforts.* This approach does not maximize return on investment, and creates expensive redundancies in programs/capabilities across the complex, hurts the quality of response, and causes unnecessary meetings/travel/coordination and other inefficiencies with no demonstrable improvement in response time or ingenuity.
- *NNSA's vision regarding Focus Area 4 of its S&T Transformation and Work With Others objective is a very positive step in the right direction.* In order to achieve that vision, however, the Laboratories must be able to respond to national needs quickly, efficiently, and at a reasonable cost. Onerous oversight or management of WFO program performance by Headquarters or site offices will put additional NNSA contributions to broader national security needs at risk.
- *Escalating Environmental Safety and Health (ES&H) and Safeguards and Security (S&S) standards have put a "squeeze" on basic research/S&T within the stewardship program.* This situation is exacerbated by the maintenance and recapitalization costs for an aging infrastructure.
- *The transition to the LLC model and continuous re-competes has led to tremendous anxiety at the Laboratories.* Technical staff, especially the younger cadre, expressed substantial concerns over the viability of their careers at the Laboratories in the face of uncertainties in management. In addition, DoE/NNSA compliance and process requirements increase the percentage of their time spent on administrative versus technical/scientific pursuits.

Recommendations

- *NNSA should work with the Laboratories and the NTS in conducting strategic prioritization of the S&T programs* to ensure that these programs are focused on national security grand challenges and on efforts that enhance capabilities that are critical to the NNSA Laboratories current and future mission(s).
- *NNSA, the Laboratories and the NTS should jointly establish and publish a clearly articulated set of criteria* for determining which national security challenges and programs are appropriate for each Laboratory's involvement based on an assessment of core capabilities and required retention/enhancement of specific expertise. Further, they should define and adhere to a uniform set of guidelines for vetting opportunities consistent with the criteria established.

- *NNSA should configure its oversight of the Laboratories and NTS to ensure performance meets the national security priorities within the bounds of budget, policy, and law.* However, the Laboratory and NTS management, personnel, and business operations should be allowed to operate unimpeded by DoE in the conduct of all laboratory operations as a Management and Operations Contractor, within the scope of accepted best business practices. The DoE should provide oversight in an audit capacity, not in a compliance capacity, to minimize unnecessarily intrusive and bureaucratic intervention. There is a need to fully restore the practice of the government-owned contractor-operated (GOCO) model.
 - *NNSA should continue the collaborative activities that are evolving as a result of Focus Area 4 and WFO activities. Any top-down strategy for WFO must merge with working level collaboration to truly succeed.* Management of WFO should be done in partnership between Headquarters (strategic focus), site offices understanding but not managing (that is the role of the M&O) any risk to DoE facilities or equipment, the Laboratories (actual implementation, including scheduling within other DoE priorities, and compliance with regulations and standards and managing all risk) and the customers (best solutions to meet their needs).
 - *DoE/NNSA must achieve consistency regarding security processes and better balance between security standards across the complex versus costs incurred – particularly at those sites without special nuclear materials – in order to decrease the burden of safeguards and security.*
- *Eliminate the Office of Intelligence and incorporate their functions back into the Central Intelligence Agency.* The IC should be able to contract directly with Labs and not go through DoE's Office of Intelligence.
- *Separate cleanup costs for past operations such that future customers do not have to subsidize the decommissioning and dismantlement (D&D) related to past operations. For future efforts, establish an allocation to build an “escrow” fund to pay for future cleanup associated with any facility or capability used.* This would be a separate allocation in the rate structure and would also have an activation date associated with the planned end of operations and subsequent D&D of a facility. (Instituting industrial best practices in this arena will achieve total life cycle cost analysis which is fundamental to good long-term strategic planning of facilities and capabilities.)
- *Manage the three NNSA Laboratories and NTS through one site office.* This would attain immediate costs savings, ensure efficient collaboration between the

laboratories, achieve needed uniformity in processes, and assure that all four entities deal with the NNSA and the non-NNSA clients in the same contractual terms.

- *Urge a quantitative and qualitative assessment, such as a National Academies of Science or Association for the Advancement of Science analysis, on the impact of decisions made under the LLC model on recruitment/retention, morale, and quality of science.*

See also Appendix V for a discussion of options to facilitate Laboratory interactions with other agencies, including reducing transaction and other costs.

Government-Wide and Inter-Agency Interface

Findings

- *Governance is the key issue.* The Laboratories and NTS need an effective coordinating entity, one that provides strategic guidance and management direction. A new governance structure would allow the US Government – including DHS, DoD, and the IC in particular – to better leverage the assets available at the Labs, thus elicit their longer-term investments. In light of the Task Force’s objective of providing a comprehensive research and development strategy, it considered different structures that would allow formulation of a USG-wide strategy and shared investment in the infrastructure it deems necessary to sustain science and technology relevant to national security needs.
- *Sustainable support of other national security agency S&T needs can be guaranteed only if the other agencies commit to long-term strategic relationships at a “sponsor” level.* These strategic relationships should entail capital investment, annual funding commitments, and participation in the long term strategic focus of the Laboratories. This requires creating a structure for multi-agency decision-making and investment and eliminating “primary” versus “secondary” access to the Labs’ capabilities. This “investment” will require commitment and support by the Office of Management and Budget (OMB), the agencies, and the Congress. This multi-agency support should reduce costs for all agency clients, while preserving these national resources and maximizing their service to the nation.
- *Diversification of investments requires a new governance “ethos.”* Additional funding will likely be required to make national security beyond nuclear weapons a core mission requirement at the Labs. It is appropriate that many agencies (DoD, DHS, Department of State, and Department of Justice) the intelligence community as well as DoE work to realize a true sense of partnership in ensuring that unique national security capabilities will be readily available when needed, rather than seeking access to these resources in a tactical

and opportunistic manner. Currently, DoE is singularly responsible for maintaining, managing, and largely funding these capabilities for the benefit of other agencies. These other agencies should now also accept the responsibility to maintain and nourish the programs that foster the needed capabilities.

- *DoD currently determines required weapon capabilities while DoE has to deal with budgetary consequences of funding and maintaining the skill sets and facilities necessary to fulfill the DoD requirements.* At present, the disconnect between DoD and DoE regarding nuclear weapons production and maintenance capabilities is complicating the existing institutional arrangements. Full engagement of DoD is required both with respect to formulating requirements as well as in making a case for the correlative budgetary needs.⁷²
- *WFO and strategic MOUs are likely too limited and too ad hoc to allow for the ideal long-range strategic planning for the S&T enterprise.* Strategic MOUs offer a flavor of shared investment for mutually desired outcomes, but they do not represent a binding financial investment and NNSA would have to arrange a large number of these tailored to each competency identified to achieve the desired effect. It is highly likely that neither WFO nor strategic MOUs can achieve the “governance” requisite to prioritize and allocate spending in a manner that ensures the appropriate long-term investments are forthcoming and most efficiently leverages the S&T base.
- *Strengthening relationships with other agencies to induce investments is critical to the long-term interests of national security.* Improved models of investment and a further reduction of barriers to investment by federal entities (especially IC, DHS, DoD) outside DoE/NNSA is necessary. Doing so will provide additional stability of funding and facilities support and enhance the Laboratories’ ability to manage and develop their capabilities.

Recommendations

The Task Force concludes that the only viable options are: 1) an overhaul of DoE/NNSA and immediate action on the recommendations outlined above or 2) a new, fully autonomous agency, with multiple financial sponsors, to provide broad national security S&T institutional mechanisms and oversight to achieve the envisioned transformation. In addition, the Task Force is mindful that: (1) NNSA never realized the degree of autonomy intended by Congress; (2) for the foreseeable future, the Department of Energy and its leadership will be fully fixated on addressing the current energy crisis; (3) shared investments can only be achieved through a governance structure that engenders strategic planning for government-wide national security science and technology needs; and (4) all government agencies need to have equal access to the science and technology capabilities at the Laboratories and NTS.

After carefully weighing the options, the Task Force concludes that creating a fully independent agency for national security science and technology will be the approach most likely to address all the findings and implement the recommendations. Moreover, a new agency has the greatest probability of achieving the optimum long-term national security S&T research infrastructure for the nation. This would enable the Laboratories to remain trusted third party advisors as well as providers of capabilities. Moreover, it initiates the transformation from a Cold War, industrial age mindset and culture to a more flexible and adaptable information age organizational structure. The proposed organizational change would catalyze the multi-agency investment schemes and synergies necessary to fully achieve the S&T transformation vision.

AGENCY FOR NATIONAL SECURITY APPLICATIONS

The Task Force proposes that fully severing NNSA and its three FFRDC design Laboratories, including NTS, from DoE to establish the Agency for National Security Applications (ANSA) has the highest likelihood of successful achievement of the S&T transformation vision. This new agency will be established with an administrator who reports directly to the President; the Administrator will be confirmed by the Senate and serve on the Board of Directors described below. ANSA will focus on anticipating the future S&T needs as required to meet our broader national security objectives. The director of the agency shall be appointed by the President and approved by the Senate.

Agency Mission

The new agency will have responsibility for: 1) designing, developing, testing components, modeling and certifying the integrity and reliability of the current nuclear weapon stockpile or any nuclear weapon modifications; 2) sustaining current, and developing new, capabilities through research, testing, and modeling performance of solutions to meet the broader US government national security needs; and 3) ensuring that the technology developed for national security clients is transferred to commercial vendors for productization, as required to meet national security agency production and long term maintenance requirements for said solutions. The production quantity and type of certain national security solutions, such as nuclear weapons, could be the responsibility of the new agency or another federal agency with national security responsibility as assigned by the Congress and the Executive Branch of the government.

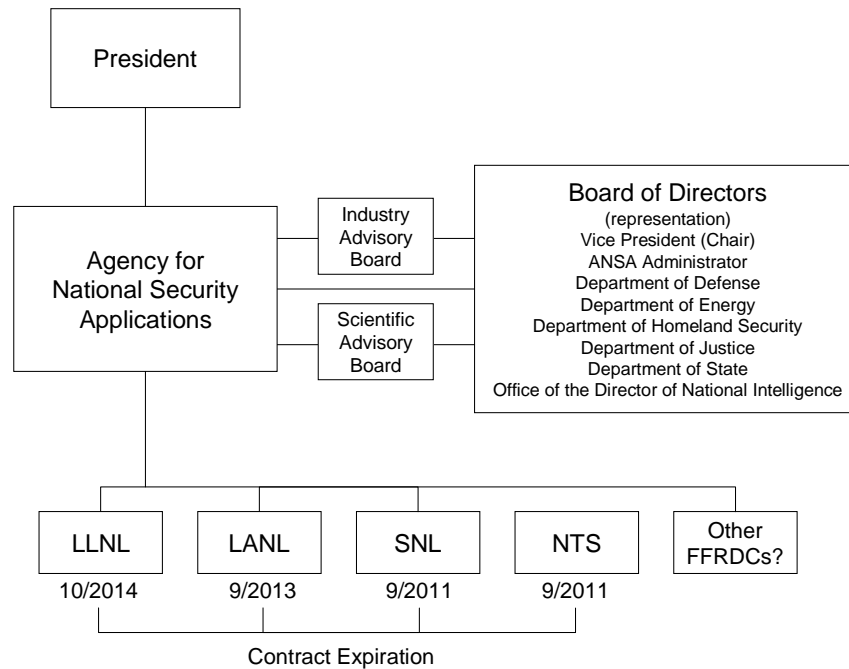
Figure 3 - Agency for National Security Applications

This agency would be responsible for maintaining capabilities and, where appropriate and legislated by Congress, to meet national security needs through developing new capability (including facilities and professional expertise) and conducting research and testing to:

- (1) Enhance US national security through the military application of nuclear energy;
- (2) Maintain and enhance the safety, reliability, and performance of the US nuclear weapons stockpile, including the ability to design, produce, and test in order to meet national security requirements;
- (3) Detect, monitor, and assess ballistic missile, cruise missile, and other such threats from space, air, land, and water vehicles;
- (4) Develop remote detection and sensing technologies as well as nuclear forensics capabilities that can be used by DoD and other intelligence gathering organizations to monitor and respond to threats;
- (5) Detect and prevent proliferation of WMD through interactions with the international community, in particular the IAEA as well as development of treaty-related verification technologies;
- (6) Model and simulate atmospheric, land, water, and infrastructure responses to hostile actions against the US or its forces;
- (7) Detect, monitor, and prevent attacks on the US cyber infrastructure, both civilian and federal; and,

- (8) Test systems and technologies developed by the agency against real-world scenarios.

The following entities would be transferred into this new agency: LLNL, LANL, SNL, and NTS. Given that Lincoln Laboratory provides many research and development functions for the DoD, the government may wish to consider that the Lincoln Laboratories would be a powerful addition to this agency, broadening the overall domain of expertise available to the greater national security community. In addition, depending on assessments of suitability, an additional FFRDC candidate might include the Pacific Northwest National Laboratory.

With the possible exception of nuclear warhead production, production of components or systems, beyond proof of concept prototypes, is not an authorized responsibility for this new agency. The agency will establish a working relationship with certified vendors to work with the agency Laboratories during concept development such that national security solutions can be productized by the commercial contractors to meet government production, deployment, and future maintenance requirements.

The oversight for safety and regulatory compliance shall be covered by the existing Federal and State regulatory bodies. Where nuclear matters are concerned, the Nuclear Regulatory Commission (NRC) guidelines will apply and the NRC will have oversight in nuclear matters.^{††}

The Task Force recognizes that the production plants have a significant and highly integrated relationship with the Laboratories. The Task Force did not address nuclear weapons production issues specifically and does not offer a recommendation regarding whether or not the plants should come under the new agency. The Task Force recognizes that if done poorly, splitting up the nuclear weapons complex and transitioning responsibilities to two separate agencies may put at risk the critical knowledge, skills and abilities that form the technical capability to assess the safety and reliability of existing US nuclear weapons (and fix them when necessary). It would be very difficult to maintain a fully integrated set of stockpile stewardship priorities. Given the role of nuclear weapons in our deterrent posture, a more thorough study of the production component of the complex is warranted.

Governance

It is proposed that ANSA be established as a new legal entity operating as an independent agency, reporting to the Executive Branch. Once the new agency is established, the DoE would commence in transitioning the operating contracts for the DoE laboratories (Management and Operating Contracts) to the new agency. Should Lincoln Laboratory

^{††} In order to ensure all requisite technical competence is available at the NRC, specifically with regard to nuclear weapons, some technical expertise from DNFSB may need to be integrated into the NRC.

prove to be a suitable fit in the new agency, the Air Force also could transfer the contract between Massachusetts Institute of Technology (MIT) and the Air Force to the new agency. Once all contracts are transferred to the new agency, the new agency would modify the FFRDC authorization to make each laboratory a multi-sponsor laboratory, with each agency that is a member of the Board of Governors a sponsor.

The new agency would have a Board of Governors that would be equivalent to a Board of Directors. The members of the board would be representatives of each Federal agency that has a desire to access on an equitable basis, any of the above mentioned laboratories or the Nevada Test site for the purpose of developing solutions that ANSA can then produce and subsequently deploy through their agency specific vendors or agency operational units. The following is a proposed Board of Governors:

- ANSA Administrator
- Department of Defense
Represented by Undersecretary of Defense for Acquisition, Technology and Logistics
- Department of Energy
Represented by the Deputy Secretary
- Department of Homeland Security
Represented by the Deputy Secretary
- Department of State
Represented by the Deputy Secretary
- Department of Justice
Represented by the Deputy Attorney General
- Office of the Director of National Intelligence
Represented by the Deputy Director
- Non-voting members are a senior National Security Council (NSC) representative and the Director, Office of Management and Budget
- The Chair of the Governing Board shall be the Vice President of the United States.

The Board of Governors will validate the mission and long term plans of the agency laboratories and NTS. This will include setting the priority of research activities, capital investment and improvements, and new research objectives of the agency in general and of the specific laboratories/sites.

The agency operating budget, including the budget for each operating laboratory and the NTS, will be proposed to the Governing Board in August of each year for approval prior to submittal to OMB. Priorities and general breadth of scope of work in support of each Department or Agency represented on the Board of Governors shall be approved by the Board of Governors prior to the beginning of each fiscal year, and prior to any major new investment.

Each sponsoring agency will also provide long-term (greater than five years) research objectives and near-term (less than five years) research, testing, modeling, or other service needs and shall commit to a minimum annual level of funding over five years. This will allow the new agency to plan for new investments and also to manage the evolution of technical expertise to meet the priorities as specified by the Board of Governors and authorized and funded by Congress.

Industry Advisory Board

There will be an external Industry Advisory Board populated by senior executives from commercial entities that currently provide products and services to at least one of the Government Agencies/Departments that are represented on the Board of Governors. Each Governor can select up to four commercial entities that can serve on the external Advisory Board. The purpose of this Board is to ensure that the agency laboratories are not unduly competing with the products and services already available from commercial vendors and to facilitate rapid transition of agency developed solutions to industry for deployment at the scale desired by the agency.

The agency laboratories will certify that the industrial vendors chosen to productize agency solutions are meeting agency designed solution performance and that the solutions comply with agency technical performance requirements.

Academic Advisory Board

There will be an external Academic Advisory Board populated by recognized academic leaders in the fields of science and engineering most relevant to the missions served by the Laboratories and NTS. Each Governor can select up to three academicians to serve on the Academic Advisory Board. The purpose of this Board will be to ensure that the research and development at the Laboratories and NTS is of the highest quality and these facilities are not pursuing areas of research more appropriate to academia. This Board will also be responsible for identifying appropriate areas and funding levels for subcontracting agency work with academic institutions to achieve the following objectives: 1) establish direct connections with academia for purposes of recruitment, 2) provide access to innovation and breakthrough ideas at academic institutions, and 3) establish a resource base of experts that can be tapped for Agency technical peer reviews.

Similar Governance Recommendations and Interagency Examples

The Task Force is mindful that other panels and commissions have called for similar governance structures to oversee the NNSA Laboratories or the weapons complex. Of the previous assessments, two in particular propose a multi-agency structure similar to that which the Task Force recommends. The 1995 Galvin Report calls for a “‘corporatized’ laboratory organization system” in which the Laboratories “will be permitted to serve the particular needs of the DoD, the DoE, as well as any others in

government, the universities, and the private sector, just as any corporation would serve its customers.”⁷³ The proposed structure included a scientific Board of Trustees, as well as advisory boards for the individual Laboratories.⁷⁴ Similarly, the DSB Task Force on Nuclear Capabilities recommended “fundamental change” of the Laboratories’ governance in the form of an independent agency to oversee the nuclear weapons complex.⁷⁵ The report clearly notes, however, that “the nuclear weapons laboratories are needed by other departments’ national security related work, especially homeland security and the IC, and are strengthened by doing that work.”⁷⁶ Therefore, to represent the diverse national needs, the Board of Directors of the new agency would be composed as described earlier.

Examples of interagency coordination on relevant issues currently exist, such as the Counterproliferation Program Review Committee (CPRC). The CPRC, composed of representatives from DoD, DoE, and the IC, is tasked with reporting on those agencies’ activities to combat weapons of mass destruction, means of delivery, and WMD-related terrorism. Despite its multi-agency composition, the CPRC calls for still greater interdepartmental communication to effectively address proliferation threats.⁷⁷ A multi-agency laboratory governance model could assist in providing that communication.

Another relevant example is the Technical Support Working Group (TSWG), a stand-alone interagency working group that identifies, prioritizes, and coordinates interagency and international R&D requirements for combating terrorism. TSWG operates under the policy oversight of the Department of State’s Coordinator for Counterterrorism and the management and technical oversight of the Department of Defense Assistant Secretary of Defense for Special Operations and Low-Intensity Conflict & Interdependent Capabilities. While TSWG’s core funds are derived principally from the Combating Terrorism Technology Support Office (CTTSO) and the Stated Department, other departments and agencies contribute additional funds and provide personnel to act as project managers and technical advisors.⁷⁸

WEIGHING THE RISKS

The Task Force acknowledges the potential for unintended consequences of the proposed reorganization. The immediate and most significant consequences would be the cost incurred and the upheaval instigated by transitioning these Laboratories and the NTS to a different institutional setting. Also, budget processes to achieve the proposed shared investments, environmental management under the new agency, and transition of the M&O contracts in the ANSA governance model need more detailed examination than what the Task Force was able to undertake within the allotted timeframe. At the same time, while the creation of ANSA obviously does not in and of itself assure success, the current institutional structures and specific political and policy environment delineated in earlier sections of this report also pose a significant risk for these Laboratories.

Through its conversations with former and current leadership at NNSA, the agencies that rely on these Laboratories, and with the Laboratories' leadership and younger scientists directly, the Task Force became overwhelmingly convinced that realization of the S&T transformation vision hinged on getting the governance piece right. The current approaches available to NNSA and the Laboratories likely cannot attain stable, long-term investments from non-DoE agencies necessary to ensure retention of the full range of needed capabilities. This is particularly true in a risk-adverse bureaucratic culture where "novel" and synergistic opportunities cannot be captured for the good of the enterprise. In addition, the current institutional arrangement cannot achieve an integrated national strategy to steward and finance a resilient, robust national security S&T enterprise. Moreover, the Task Force believes that the immediate costs incurred by restructuring would be recouped and surpassed over time through the savings derived by eliminating existing redundancies, leveraging the S&T investments in a much more efficient manner, and reducing time needed to respond to diverse agency needs. For these reasons, the Task Force believes that the risk to our national security S&T future is greater if bold action is not undertaken.

CONCLUSION

In early 2008, the Stimson Center convened a bipartisan Task Force to provide the new administration with a roadmap to more effectively leverage the existing capabilities at the NNSA Laboratories and Nevada Test Site to meet an array of vital national security challenges. The Task Force pursued the formulation of a comprehensive strategy to attain two key interrelated objectives: to ensure retention of core nuclear weapons competencies while better leveraging these core S&T capabilities to service an array of contemporary national security needs. Ultimately, the vision was the creation of a “21st century national security S&T enterprise” – a resilient, robust set of capabilities to service our nation’s national security needs.

NNSA and the Labs essentially have three tools with which to achieve such synergies between the traditional nuclear weapons mission space and the ongoing work for other non-DoE agencies. These tools include: (1) Strategic Memorandums of Understanding; (2) Work-for-Others; and (3) Industry Partnerships. The Task Force found that each of these tools had significant limitations in creating the conditions for non-DoE agency investments and retention of the full array of capabilities necessary to effectively respond to today’s burgeoning national security S&T challenges.

Only the strategic MOUs with other national security agencies offer the possibility of a “long-term investment” of mutual interest. However, the main limitations of these MOUs include: a serious question regarding the number and variety feasible to ensure retention of a broad range of capabilities and the non-binding nature of the funding commitment. In addition, this approach allows for a “bilateral” investment in a shared objective, but it does not attain strategic planning and prioritization across the range of national security S&T needs. Most importantly, shared investments require equal access to the capabilities among the parties in order to elicit strategic investments.

The Laboratories have long operated as broad national security institutions through their WFO activities for non-DoE customers. However, WFO is largely a piecemeal, tactical approach to pursuing synergistic efforts; it does not conform to an integrated government-wide strategy that would maximize synergies and fully leverage the S&T investments. As current and former Lab Directors repeatedly suggested to the Task Force, these Laboratories cannot be sustained, much less thrive, if they remain reliant on hundreds of short-turnaround, small budget activities. In addition, it would be hard to conceive of achieving the coordination necessary to allow the Laboratories sufficient autonomy to compete for WFO opportunities at all the relevant agencies, while remaining in accordance with and servicing a government-wide national security S&T strategy.

Lastly, all of the Laboratories pursue opportunities with industry partners. However, this aspect of the Labs' non-DoE customer work falls particularly short in its ability to have a significant impact on the Laboratories' future. Other than some fairly lucrative CRADA activities with a handful of companies, the Labs only infrequently "team" with industry in a long-term, effective manner that is mutually beneficial. In those identifiable and significant cases, CRADAs are clearly mutually advantageous. However, in most instances industry comes to the Labs for solutions to a specific problem – not for purposes of sustained collaboration. Moreover, the Task Force saw no evidence that the industry partnerships portfolio could grow to a level requisite to offset any significant declines in nuclear weapons budgets.

In addition to the limitations of the tools themselves, the Task Force repeatedly confronted two mutually reinforcing higher order conditions of detriment to the vision's realization. First, NNSA never achieved the necessary autonomy from DoE to avoid the pervasive management problems and cultural impediments identified by other panels and commissions throughout the 1990s. DoE's risk averse and overly bureaucratic culture has permeated NNSA, further limiting the application of these tools. Even the most lucrative and synergistic non-DoE opportunities available to the Labs confront painstaking processes and require approval across numerous stovepipes. Second, the sense of partnership between DoE/NNSA and the Laboratories is clearly fractured, if not broken. A sensitive balance must be restored between headquarters and the Laboratories, one in which the DoE/NNSA provides clear strategic direction and defines the objectives, and the Laboratories identify the path and implement the steps toward achievement. Given the limited tools available and institutional parameters at hand, the Task Force did not believe that the vision would be attainable without major changes in the governance architecture for the Laboratories and NTS.

After a careful weighing of the options, the Task Force strongly recommends the creation of a fully independent agency for national security science and technology, the Agency for National Security Applications (ANSA). ANSA would operate as an autonomous agency with multiple financial sponsors across the national security community to provide integrated strategic planning and oversight. Lastly, the proposed organizational change would catalyze the multi-agency investment schemes and synergies necessary to fully achieve the transformation vision and fully maximize the return on these S&T investments.

— APPENDIX I —
TASK FORCE MEMBERS

FRANCES FRAGOS TOWNSEND (CO-CHAIR)

Former Assistant to President Bush for Homeland Security and Counterterrorism



Ms. Frances Fragos Townsend served as the Assistant to President Bush for Homeland Security and Counterterrorism from 2004 to 2008. She previously served as Deputy Assistant to the President and Deputy National Security Advisor for Combating Terrorism. Ms. Townsend came to the White House from the US Coast Guard, where she had served as Assistant Commandant for Intelligence. Prior to that, Ms. Townsend spent 13 years at the US Department of Justice in a variety of senior positions, including Director of the Office of International Affairs in the Criminal Division, Acting Deputy Assistant Attorney General in the Criminal Division, and Counsel for Intelligence Policy.

LT. GEN. (RET.) DONALD KERRICK (CO-CHAIR)

Former Deputy National Security Advisor to President Clinton



Lieutenant General Donald Kerrick is the former Deputy National Security Advisor to President Clinton. General Kerrick also served as Assistant to the Chairman of the Joint Chiefs of Staff from August 1999 to July 2000. Prior to that, he served at the White House as the Deputy Assistant to the President for National Security Affairs from January 1997 to August 1999. Lieutenant General Kerrick has served on the White House's National Security Council as Director of European Affairs and as the White House and National Security Council representative on the United States' Balkans Peacekeeping Delegation. Lieutenant General Kerrick's combat experience includes service in Southeast Asia and Southwest Asia (Desert Storm). He has commanded a Military Intelligence Company, an Aviation Company, a Military Intelligence Battalion (Aerial Exploitation), and a Military Intelligence Brigade. Lieutenant General Kerrick also served as the Director of Operations for the Defense Intelligence Agency where he was responsible for the Defense HUMINT Service and Defense Attaché System. His staff assignments included service with the US Army Berlin, the US Army Intelligence and Security Command, the Third Army, the Army Staff, the Joint Staff, the National Security Council, and the White House.

ELIZABETH "LIBBY" TURPEN (PROJECT DIRECTOR)

Senior Associate, The Henry L. Stimson Center

Dr. Turpen is the co-director of the Cooperative Nonproliferation Program and the director of the Security for a New Century Program at The Henry L. Stimson Center. She brings recent Senate experience and a background in national security, nuclear, and nonproliferation issues

to these projects. Dr. Turpen previously worked for Senator Pete V. Domenici (R-NM) as a legislative assistant responsible for defense, nonproliferation, and foreign affairs. Before coming to Washington in 1998, she was a consultant on nonproliferation policy, US-Russia programs, and the national security implications of technological advances for a high-tech company in New Mexico. She has extensive teaching experience and has published numerous articles. Dr. Turpen received her Ph.D. from the Fletcher School of Law and Diplomacy at Tufts University.

JONAH J. CZERWINSKI

Managing Consultant, Global Business Services, IBM

Senior Fellow for Homeland Security, IBM Global Leadership Initiative

Jonah Czerwinski is Managing Consultant, Global Business Services, at IBM and a Senior Fellow for Homeland Security in IBM's Global Leadership Initiative. Mr. Czerwinski is also a Senior Advisor for the Center for the Study of the Presidency and serves on the Board of Directors of the Partnership for a Secure America. From 2003 to 2006, Mr. Czerwinski was Senior Research Associate and Director of Homeland Security Projects at the Center for the Study of the Presidency. Prior to joining the Center in late 1999, Mr. Czerwinski was an Analyst with the program in International Finance and Economic Policy and a Research Assistant to the CEO at the Center for Strategic and International Studies.

MELANIE L. ELDER

Senior Science & Technology Advisor, National Counterproliferation Center

Dr. Melanie L. Elder is the Senior Science and Technology Advisor to the Director of the National Counterproliferation Center (NCPC) in the Office of the Director of National Intelligence. Dr. Elder is responsible for advising the Director on S&T issues related to the development, acquisition, deployment, or use of weapons of mass destruction by proliferant states and non-state actors; the research and development of capabilities to assess, collect against, or interdict activities of proliferation concern; and the development of integrated strategies to counter these threats. Dr. Elder joined NCPC in 2006 after sixteen years of service at Lawrence Livermore National Laboratory (LLNL), where, for nearly five years, she was Z Division Leader, the International Assessments and Information Operations Program Leader, and the Chief of the Department of Energy's Field Intelligence Element. She received the Department of Energy Distinguished Career Service Award in February 2006. Before joining LLNL, Dr. Elder was a Senior Research Scientist at Corning, Inc. and received Corning's highest recognition as an individual contributor in 1988. She holds two US patents and one European patent for her research at LLNL and Corning, Inc.

DELORES M. ETTER

*Director, Caruth Institute for Engineering Education, Southern Methodist University
Texas Instruments Distinguished Chair in Engineering Education, Southern
Methodist University*

Dr. Delores M. Etter is the Director of Southern Methodist University's new Caruth Institute for Engineering Education and the Texas Instruments Distinguished Chair in Engineering Education. She served for two years as the Assistant Secretary of the Navy for Research, Development and Acquisition. Prior to that, she held several academic positions, including stints at the US Naval Academy, the University of Colorado, Boulder, the University of New Mexico, and Stanford University. Dr. Etter also served as the Deputy Under Secretary of Defense for Science and Technology from 1998 to 2001.

STEPHEN J. GUIDICE

*Former Head of the Office of National Defense Programs at the DoE Albuquerque
Operations Office (DoE/AL)*

For the past 10 years, Mr. Guidice has been an independent consultant advising the DoE nuclear weapons Laboratories, production plants, the Nevada Test Site, the Pentagon, and Congress. In his 20-year career at DoE/AL, he served in many different leadership positions in the nuclear weapons program, including more than 12 years in Senior Executive Service assignments. He served as Director of the Weapons Production Division, Director of the Weapons Quality Division, and Head of the Office of National Defense Programs with about a \$2 billion annual budget. For the last two years, he served as the Head of the Office of Energy, Science, and Technology, managing a combined \$1 billion per year Work-for-Others program at Sandia and Los Alamos National Laboratories.

MARKKU KOSKELO

Deputy Director of Safeguards, CANBERRA Industries Inc.

Dr. Markku Koskelo is presently the Deputy Director of Safeguards for Canberra Industries Inc. and Vice President of Special Projects for Canberra Albuquerque Inc. He is the director, senior advisor, and project coordinator for all CANBERRA safeguards business associated with the national and international safeguards organizations such as the IAEA, Euratom, and the Brazilian-Argentine Agency for Accounting and Control of Nuclear Materials (ABACC). A former Chief Scientist for Canberra Industries, Inc., he continues to be a senior scientific advisor on technology transfers from research establishments such as the DoE laboratories. He is a permanent member of CANBERRA's Intellectual Property Committee. Dr. Koskelo also continues to be a senior advisor for CANBERRA's Homeland Security efforts. He joined Canberra Industries in 1982 and has held many technical and management positions with the company, including Vice President of CANBERRA's Nondestructive Assay Systems business line, Vice President of Science and Technology across all product lines and technologies worldwide, and Vice President of Marketing responsible for product direction activities worldwide.

THOMAS J. LANGE

Director, Modeling and Simulation, Global Capability Organization Research and Development, Procter & Gamble

Mr. Thomas Lange is the Director of Modeling and Simulation for Procter & Gamble (P&G). He joined P&G in May 1978 as a Product Technical Engineer. Mr. Lange has spent his nearly 30 year career modeling and simulating products and production systems—from how the aerodynamics of peanuts affect roasting, to how baby sizes affect the probability of a urine leak in a diaper. In 1994, Mr. Lange was recognized with a PRISM award (Professional Recognition of Individual Sustained Mastery) – P&G’s highest technical recognition award for Engineering. In 1998, he was appointed Associate Director for Computer Aided Engineering (CAE) in Baby Care, and Reliability Engineering responsibilities for all P&G Paper goods including Always, Charmin and Bounty. In August 2004, Mr. Lange was appointed Director, Modeling & Simulation (M&S) in Corporate R&D with responsibilities including Computational Chemistry. In July 2008, he was named Director, Modeling & Simulation Global Capability Organization, R&D. In this position, Mr. Lange leads P&G’s M&S efforts ranging from Computational Chemistry, Computer Aided Engineering (CAE) to Process, Reliability, and Supply Chain Analysis. He received a BS in Chemical Engineering from the University of Missouri in 1978.

RANDALL S. MURCH

Associate Director, Research Program Development, Research Division, National Capital Region, Virginia Polytechnic Institute and State University

Dr. Randall S. (Randy) Murch is the Associate Director for research program development in the Research Division of Virginia Polytechnic Institute and State University of the National Capital Region. He also holds adjunct professorships in the School of Public and International Affairs, College of Architecture and Urban Studies, and the Department of Plant Pathology. From February 2007 until January 2008, Dr. Murch served as a detailee under the Intergovernmental Personnel Act from Virginia Tech to the Department of Homeland Security, Directorate of Science and Technology, Office of Research. From 2002 to 2004, Dr. Murch was on the research staff of the Institute for Defense Analyses (IDA). Prior to working at IDA, Dr. Murch served for 23 years as a Special Agent with the Federal Bureau of Investigation (FBI). He worked as a Department Head and Deputy Division Head in the FBI Laboratory, as well as a Deputy Division Head of the FBI’s electronic surveillance division (investigative technology). From 1999 to 2001, he was detailed to the Defense Threat Reduction Agency (DTRA) as Director of DTRA’s advanced systems and concepts office.

DAVID O. OVERSKEI

President, Decision Factors, Inc.

Dr. Overskei is the President of Decision Factors, Inc., providing corporate and government agency management with strategic analysis of complex programs and issues, guidance on future technology, and program implementation plans. Dr. Overskei also provides technology evaluation for corporations and venture capital firms. Previously, Dr. Overskei was President and CEO of Polexis, an Enterprise Data Integration software company headquartered in San

Diego, California. He has also served as Senior VP for Strategy, Mergers and Acquisitions at SAIC and held executive positions at General Atomics and was a principal research scientist at MIT. Dr. Overskei chaired the Secretary of Energy Advisory Board Task Force on the Nuclear Weapons Complex of the Future.

AMY SANDS

Provost, Monterey Institute of International Studies

Dr. Amy Sands is the Provost of the Monterey Institute of International Studies. Prior to becoming Provost, Dr. Sands held two other positions at the Monterey Institute: Dean of the Graduate School of International Policy Studies for three years and the Deputy Director of the Center for Nonproliferation Studies for seven years. From August 1994 to June 1996, she was Assistant Director of the Intelligence, Verification, and Information Management Bureau at the US Arms Control and Disarmament Agency (ACDA). Before joining ACDA, she led the Proliferation Assessments Section of Z Division (Intelligence) at the Lawrence Livermore National Laboratory and was Country Risk Manager of New England Merchants Bank.

BENN TANNENBAUM

Associate Program Director, Center for Science, Technology and Security Policy, American Association for the Advancement of Science

Dr. Benn Tannenbaum is Associate Program Director at the Center for Science, Technology and Security Policy at the American Association for the Advancement of Science (AAAS). Prior to joining AAAS, Dr. Tannenbaum worked as a Senior Research Analyst for the Federation of American Scientists (FAS). Before joining FAS, Tannenbaum served as the 2002-2003 American Physical Society Congressional Science Fellow. During his fellowship, Dr. Tannenbaum worked for Representative Edward J. Markey (D-MA) on nonproliferation issues. He has testified before the US House of Representatives Committee on Homeland Security. Dr. Tannenbaum has authored or co-authored over 160 scientific and policy-related publications.

— APPENDIX II —

STATEMENT OF WORK

LEVERAGING NNSA NATIONAL LABORATORY SCIENCE AND TECHNOLOGY FOR 21ST CENTURY SECURITY

CONTEXT AND OBJECTIVES

In 2006, the National Nuclear Security Administration (NNSA) unveiled a plan to establish a smaller, more efficient Nuclear Weapons Complex that could respond to new and emerging security challenges. Although differing in several key ways, this plan was broadly based on the Secretary of Energy Advisory Board's earlier "Nuclear Weapons Complex of the Future" study. Unfortunately, neither of these plans systematically assesses the potential application of the immense scientific and engineering talent housed at the NNSA national security Laboratories to meeting current and future national security challenges beyond their core nuclear weapons mission and none of the existing public studies looks in a comprehensive manner at leveraging the ongoing "work for others" (WFO) portfolio at the Laboratories to devise an integrated, synergistic research and development (R&D) strategy for addressing national security needs.

The implementation of a strategy focused narrowly on the nuclear weapons mission risks the loss of expert knowledge and capabilities that could be applied to solving urgent national security problems. And, compounding this, such existing internal strategic planning by NNSA that does take a more expansive view of nuclear complex transformation will be challenged to find support in future administrations or Congress. To address this gap – and go beyond the current complex transformation discussion – the Stimson Center will assemble and lead a Task Force that will assess, develop and promote an integrated R&D strategy for the NNSA national security Laboratories.

This initiative aims to achieve a "win-win" future based on the following assumptions:

- Ensuring a robust and capable national laboratory system to meet 21st century security challenges and
- Retaining and applying the scientific and technological talent resident at the laboratories to a diverse array of national security needs is in the best interest of the US and its citizens.

A strategic plan for applying the existing scientific talent and capabilities at the laboratories to address the nation's burgeoning national security challenges is an urgent priority. Such a plan will help to ensure that S&T capabilities are not eviscerated as the nuclear weapons "footprint" is reduced.

Key audiences for this project include Members of Congress, current and future DoE/NNSA and laboratory officials, officials at other agencies, as well as science, technology, and national security specialists. The project will promote its vision widely to gain broad-based support for its recommendations.

PROJECT METHODOLOGY AND ACTIVITIES

Articulation of a broader vision for the NNSA National Security Laboratories is critical in retaining the premier scientific capacity residing at these facilities. The S&T base afforded through the substantial historical investments in the US nuclear deterrent has yielded national security gains in the country's efforts on counterterrorism, homeland security, and cyber security, as well as needed support for the intelligence community. Maximizing the synergies between ongoing "work for others" at the Laboratories and the retention of core nuclear weapons competencies requires a comprehensive look at the ongoing non-nuclear weapons work, its application to current challenges, and its nexus with the Laboratories' traditional mission. This project will serve to provide a comprehensive strategy and vision for attaining the desired "21st century national security enterprise."

The Stimson Center is prepared to inform and advance that vision by undertaking the following activities:

- Conduct a scoping study of both the missions and budgetary means currently applied to the nuclear and non-nuclear weapons work at the NNSA National Security Laboratories as read-ahead materials for the members of the Task Force. More detailed information regarding current activities and budgetary resources will be presented to the Task Force by Laboratory personnel at meetings in Albuquerque, New Mexico, and Livermore, California.
- Organize a Task Force comprising of former DoE/NNSA and laboratory officials, specialists from other agencies, as well as technology entrepreneurs and national security experts. As a collective expert body, the Task Force will encompass the appropriate experience and skills, as well as gravitas, needed to lend credibility and a high profile to this initiative.
- Convene four workshops with the Task Force (two in Washington, DC, one in New Mexico and one in California) to discuss ways to diversify and channel the existing S&T expertise into solving other national security needs, including formulation of viable models for the "work for others" at the Laboratories.
- Produce and disseminate a consensus report based on the findings of the scoping study, as well as the insights voiced at the workshops by participants. The dissemination plan will include Internet and print media outreach, both nationally and targeting relevant communities.

- Provide briefings to key stakeholders, especially incoming administration officials, as well as conduct outreach to media outlets on the findings and recommendations from the final report.

PROJECT DELIVERABLES

1. A comprehensive report that describes a more expansive vision of “Complex Transformation.” It will provide a strategic plan and approach for applying the existing scientific talent and capabilities at the laboratories toward addressing pressing national security challenges. Ultimately, it will provide a tangible framework to help the US government make smarter use of this rich scientific base, and allow NNSA to retain core competencies by leveraging the investments of other agencies.
2. Targeted outreach with key stakeholders (i.e., incoming administration officials in key agencies/offices, congressional offices, local communities) to elicit both a positive reception to and a willingness to push for implementation of the report’s findings and recommendations.

— APPENDIX III —

GENERAL COOPERATIVE RESEARCH AND DEVELOPMENT AGREEMENT GUIDANCE

As a key vehicle for the Laboratories to interface with industry in a collaborative enterprise, the Stimson Task Force spent a significant amount of time collecting information and assessing the value of Cooperative Research and Development Agreements (CRADAs). Below are some general findings and recommendations, a generic description of CRADAs, as well as a lengthier discussion of the advantages and disadvantages that this vehicle confers upon the parties.

FINDINGS

- *A CRADA allows the commercial partner to “draft” the national Laboratories in their access to government programs normally unavailable through commercial marketing. The positive effect of this access to a government market often outweighs the legal impediments described below and, in most cases—especially in “niche markets,” may be the only route to market.*
- *An “umbrella CRADA” allows industry and the Labs to agree on a general area of joint research and add additional tasks/capabilities as the project progresses. This avoids having to negotiate individual CRADAs for each discrete effort. However, it is important to balance this advantage against criticism of favoritism toward certain companies to the exclusion of competitors.*
- *Potential risks to industry include: variability in interpretation and implementation of CRADA language giving rise to insufficient predictability, the lack of financial transparency by DoE Laboratories, problems with non-exclusive royalty-free license provisions, and control of derivative works emanating from the CRADA.*

RECOMMENDATIONS

- *Encourage increased use of umbrella CRADAs in order to make partnership with the Laboratories more attractive while reducing transaction costs.*
- *Provide mechanisms to enhance the ability of commercial partners to develop derivative products in markets served by the commercial partner. Laboratory follow-on work in related areas should focus on sustaining capabilities needed for national security science, and not on developing derivative applications.*
- *Establish and enforce uniform guidelines regarding interpretation of CRADA language in order to increase predictability for attracting industry collaboration with the Laboratories.*

- *Develop and adhere to clear directives regarding exclusivity.*

GENERAL DESCRIPTION AND ASSESSMENT OF CRADAS

A CRADA is a written agreement between a DoE Laboratory and a non-federal party (Participant) to work together as partners on a research project of mutual interest.

A CRADA consists of:

- General provisions in a standardized format that provide the legal framework for the agreement; and,
- A Statement of Work (SOW) describing the objectives, tasks, and deliverables of the collaborative project.

Under a CRADA, the DoE Laboratory may provide the collaborator or the collaborator may provide the DoE Laboratory either:

- Personnel, services, facilities, equipment, and/or other resources, or
- The collaborator may provide funds to the DoE Laboratory; the DoE Laboratory does not provide funds to the collaborator.

The legal CRADA agreement template defines all the usual legal issues that are needed to execute the agreement. In particular, it includes the definition of the key terms or phrases, explains the role of a SOW, defines the terms of funding and conduct related to the funding, addresses personal property, product liability, obligations of the parties to safeguard proprietary and CRADA generated information, export control reports, and copyright and title issues related to any inventions. It also defines the license terms and conditions as well as several other aspects. Many elements are not defined in the legal CRADA template agreement while other guidance, specifically the DoE/NNSA Master template dated June 1, 2006, leaves room for interpretation.

From the perspective of a participating commercial entity, the template defines what is considered “Background Intellectual Property,” the title of which shall remain with each participant as it existed prior to the CRADA. This is a key protection point for the participating commercial entity. The CRADA template should and is primarily interpreted to address the “Subject Inventions,” i.e. inventions first conceived or reduced to practice by either DoE or the participant under the CRADA. The following excerpts from the CRADA wording are problematic:

- (1) Under the CRADA framework, “the Government has for itself and others acting on its behalf, a royalty-free, nontransferable, nonexclusive, irrevocable worldwide Copyright license to reproduce, prepare derivative works, distribute copies to the public, and perform publicly and display publicly, by or on behalf of the Government, all Copyrightable works produced in the performance of the CRADA, subject to the restrictions this CRADA places on publication of Proprietary Information and Protected CRADA Information.”

- (2) Under the CRADA framework, the “Copyrighted computer software produced in the performance of this CRADA, the Party owning the Copyright will provide the source code, an expanded abstract as described in Appendix B, the executable object code and the minimum support documentation needed by a competent user to understand and use the software to DoE/NNSA’s Energy Science and Technology Software Center, P.O. Box 1020, Oak Ridge, TN 37831.”
- (3) Under the CRADA framework, “any Copyrighted computer software produced in the performance of this CRADA, DoE/NNSA has the right, at the end of the period set forth in paragraph B of Article VIII hereof and at the end of each two-year interval thereafter, to request [the DoE Laboratory in question] and the Participant and any assignee or exclusive licensee of the Copyrighted software to grant a nonexclusive, partially exclusive, or exclusive license to a responsible applicant upon terms that are reasonable under the circumstances, provided such grant does not cause a termination of any licensee's right to use the Copyrighted computer software. If [the DoE Laboratory in question] or the Participant or any assignee or exclusive licensee refuses such request, [the DoE Laboratory in question] and the Participant agree that DoE/NNSA has the right to grant the license if DoE/NNSA determines that [the DoE Laboratory in question], the Participant, assignee, or licensee has not made a satisfactory demonstration that it is actively pursuing commercialization of the Copyrighted computer software.”
- (4) “Wherein DoE/NNSA has granted the Participant and [the DoE Laboratory in question] the right to elect to retain title to their respective Subject Inventions, and wherein the Participant has the option to choose an exclusive license, for reasonable compensation, for a pre-negotiated field of use to [the DoE Laboratory’s] Subject Inventions.”
- (5) “The Parties acknowledge that the Government retains a nonexclusive, nontransferable, irrevocable, paid-up license to practice or to have practiced for or on behalf of the United States every Subject Invention under this CRADA throughout the world. The Parties agree to execute a Confirmatory License to affirm the Government’s retained license.”
- (6) The “Participant has a separate option, under each Project Task Statement (PTS), to obtain up to and including an exclusive license, for reasonable compensation, for a pre-negotiated field of use, to [the DoE Lab’s] Subject Inventions arising under such PTS. Accordingly, the Parties agree to enter into a separate Option Agreement for each Project Task Statement with mutually agreed terms and conditions.”

Any attempt by a prospective Participant to change the wording of the DoE/NNSA approved template at the level of the Laboratory is an exercise in futility. No wording changes are ever permitted.

The assessment below outlines the key advantages and disadvantages of the CRADA as a mechanism for industry partnership with the DoE Laboratories.

ADVANTAGES

- (1) The benefit of the CRADA is that it fosters joint work between the industrial partner and the DoE Lab. This is imperative in making the inventions developed prior to and during the CRADA practical to manufacture, ship, and support/service long-term.
- (2) The other benefit of the CRADA is that it clearly specifies how the intellectual property (IP) that has been generated prior to during the CRADA is to be protected, particularly the rights of one party in case the other party chooses not to protect the IP.
- (3) The CRADA language gives the USG several rights, which, from a strictly legal perspective, can be very problematic for a commercial entity. However, the government rarely exercises those rights for use of the inventions first developed under a CRADA. Therefore, the commercial partner can enjoy the benefits of the CRADA results with a few exceptions as mentioned below.

DISADVANTAGES

- (1) The CRADA process is being used as a means to acquire funding for the DoE Laboratories. As the Laboratories' budgets get reduced, there is an incentive for the Labs to pursue additional CRADAs where all the money comes from an external partner. This leads to a situation where an immediate financial incentive may outweigh long-term strategic interests.
- (2) In CRADAs that are completely funded by the commercial partner, the rights to the inventions produced under the CRADA are still treated as if the Laboratory were funding all of its own work. For example, the commercial Participant still needs to pay an up-front license fee and a royalty for the device created during the CRADA, even if the Participant paid for all of the development. In any purely commercial contract R&D, the complete IP rights would always remain with the paying entity and there would be no license fees or royalties due to the party doing the work.
- (3) Financial reporting by the DoE Lab is often insufficient. If the CRADA process is used in such a way that the commercial partner provides the funding, there is no mechanism to report how the industry contributions are being spent. Without financial reporting, it is next to impossible for the commercial partner to claim that the IP generated by the CRADA fully funded by the commercial partner belongs to the commercial partner free and clear without license fees and royalties.
- (4) The government has a right to retain a non-exclusive royalty free license to use the inventions for its own purposes. Particularly for NNSA related activities, these

purposes tend to support DoE activities, as DoE often the most logical customer for the commercial partner's CRADA invention(s). There are a few examples where the government has made subsequent purchases of systems from the DoE Laboratory and not from the commercial partner that licensed the technology.

- (5) CRADA wording often allows the government to develop derivative works from the inventions first generated under the CRADA. It is customary and logical for the commercial partner to develop derivatives from the original inventions as part of their normal business. It is also common that the original DoE Laboratory will continue to develop the concepts and produce items similar to the derivative works developed by the commercial partner, thereby creating a competitive situation, something that the law explicitly specifies the Laboratories are not supposed to do. A more appropriate method would be for the government (DoE) to contract the commercial partner to develop the derivatives. In practice, the Laboratory sometimes continues its further development even on technology that has been fully commercialized.
- (6) CRADAs require that any software developed in the course of the CRADA be placed in the Energy, Science, and Technology Software Center. This Center allows for any other DoE entity to obtain the software free of charge. Again, the most common customer for the software developed under CRADAs are other DoE or government entities. Placing the software into this center negates any commercial incentive to develop such software as part of the overall solution under a CRADA.

Given the above discussion: Why should a commercial company enter the CRADA process? The answer is that they should, if the real value of the CRADA exists beyond the legal impediments defined above. In practice, the government has rarely exercised rights to the detriment of the commercial partner, and other than "march-in rights" should the commercial partner abandon the project, one has to view the CRADA as a marketing vehicle.

— APPENDIX IV —

WORK FOR OTHERS

Work for Others (WFO) is a reimbursable DoE program that governs the performance of work by all primary DoE organizations and NNSA personnel and/or their respective contractor personnel for non-DoE entities. It also includes the use of DoE/NNSA facilities (with some exceptions) for work that is not directly funded by DoE/NNSA appropriations. Partner entities can include other US federal agencies, commercial companies, local and state governments, as well as foreign governments.

WFO has four objectives:

- First, it allows DoE/NNSA to provide assistance to federal agencies and non-federal entities to accomplish goals that may be otherwise unachievable and to avoid duplication of effort at federal facilities.
- Second, it provides non-DoE/non-NNSA entities with access to highly specialized or unique DoE/NNSA facilities, resources, services, and/or technical talent in the event that private sector facilities prove to be inadequate.
- Third, it increases R&D interaction between DoE/NNSA facilities and private industry whereby technology originally developed at DoE/NNSA facilities can be transferred to industry for further development or commercialization.
- Last, it helps maintain core DoE/NNSA competencies and enhances the S&T base at DoE/NNSA facilities.⁷⁹

WFO can also include requests for non-R&D services, as long as the work requested is consistent with the mission and/or special expertise of the DoE/NNSA facilities. The work requested must also not affect the achievement of DoE/NNSA mission requirements and must not directly compete with the US domestic private industry. While the USG retains a non-exclusive royalty-free license to any WFO invention, title to invention of WFO sponsor's requirement goes to the sponsor under the class patent waiver and the sponsor's proprietary data is always protected.⁸⁰

The ongoing success of the WFO program led NNSA senior management to realize the program's potential in becoming a strategic asset for the NNSA complex and its transformation. In the past years, the WFO program has grown to be recognized as a key element in developing, enhancing, and sustaining the nuclear weapons complex's highly specialized capabilities associated with its workforce, facilities, and infrastructure. About 15-20% of the NNSA Complex workforce is currently engaged in WFO activities. FY 2006 WFO revenues for the NNSA were estimated to be \$1.5 billion.⁸¹ In FY 2007, NNSA tasked its Office of Institutional and Joint Programs (OIJP) to commission an Executive Committee that included NNSA/OIJP, the NNSA facilities, and their associated site offices, to identify creative approaches to evolve the WFO program into a national strategic asset for the NNSA Complex. This effort led to the creation of the new WWO concept.

WFO differs from WFO in that WWO is an overarching concept geared towards transforming the NNSA culture from one of *working for others* to one of *partnering with others*. WWO focuses on: streamlining Reimbursable Programs, such as the WFO; establishing strategic alliances with key national security partners, such as federal agencies with national security missions (e.g. DoD, DHS and the IC in general); enhancing interactions with industry and academia; and providing integrated solutions to national security challenges.

The WWO mission is to deliver advanced Science, Technology, and Engineering (ST&E) capabilities to maintain US national security technological superiority and preparedness. It aims to enhance the ability of Other Federal Agencies (OFA) and Non-Federal Entities (NFE) to work effectively with NNSA facilities in response to national security needs by:

- (1) streamlining and simplifying the Reimbursable Programs' business rules and existing governance models;
- (2) partnering with OFAs by effectively utilizing the NNSA and OFAs' ST&E capabilities and developing co-investment in ST&E resources, infrastructure, shared financial, technical, and business risks as well as operational arrangements;
- (3) integrating the NNSA Complex's overall capabilities across its various facilities by improving the NNSA's internal understanding of the facilities' individual capabilities and emphasizing the importance of ST&E collaboration as per each facilities' in-house resources and expertise; and
- (4) cultivating increased interactions between NNSA facilities and NFEs through improved outreach activities.⁸²

— APPENDIX V —

EXPANDING OPPORTUNITIES AND STREAMLINING WFO PROCESSES

The following recommendations only apply if the “Governing Board” concept (outlined on pages 46-48) proves infeasible or does not obtain a multi-agency strategy regarding national security S&T priorities and shared investments in capabilities. In addition to strategic alliances, NNSA should work with the Laboratories to develop and implement the following business models and development practices:

- (1) *Create realistic and affordable models for other-agency investment in facilities:* NNSA should work with the OMB to develop approved and legally sound models for other agencies to jointly or solely invest in NNSA Laboratory facilities. Such investments must contain appropriate protections of the participating agencies’ interests, including life cycle responsibilities. Also, clear guidelines must be established regarding their use as multi-agency facilities. Establishing such models will greatly reduce transaction costs and ameliorate other agencies’ uncertainties about the future of potential investments. In addition, the ability to develop facilities at an NNSA Laboratory in a mutually beneficial manner will allow agencies to expand longer-term thinking about R&D investment at the Laboratories and can be a catalyst for further strategic engagement. Once such models and guidelines are established, NNSA and the site offices should promote, rather than prohibit, their use.
- (2) *Promote “umbrella” Agreements with Laboratories:* For agencies that invest more significant sums at a Laboratory but prefer increased investment flexibility and a closer relationship with the Laboratory capability, a model similar to an “Umbrella CRADA” may prove to be a useful vehicle. This immediately reduces transaction costs compared to multiple task order agreements, yet allows tasking to be flexible and agile—a strong desire of many customers. NNSA would join the Laboratory and the customer/partner agency as part of a decision/portfolio review board that would provide an annual review of the R&D portfolio, opportunities, and issues. Creating these Umbrella agreements between agencies and the Laboratories would also allow them to be tailored to Laboratory capabilities, culture, and strengths. Umbrella agreements capturing the understanding of shared interests between a particular Laboratory and customer, and a few pilots aligned with them, lead to organic growth. The Laboratories have successful models of such relationships in Umbrella CRADAs.
- (3) *Establish a single umbrella Basic Ordering Agreement (BOA) contract between non-DoE agencies and the NNSA Laboratories & NTS.* The agreement would address all

generic intellectual property (IP), cost, compliance, general contracting, and liability issues with multi-year provisions. Once signed, the non-DoE agency can go to any of the weapons Laboratories or NTS to negotiate the actual cost and schedule for the specific activity as a Task Order. The types of work allowed to be performed under this BOA would be identified in the BOA.*

- (4) *Invigorate partnerships within DoE*: Partnerships with the rest of the DoE, including the OS laboratories, are at least equally as important as those with other agencies; DoE operating and facility investment in the NNSA Labs is significant. Enhancing intra-departmental partnerships should be an immediate priority, particularly since DoE is a major non-NNSA customer and investor in the NNSA Laboratories and has a track record of some significant facility investment. Future DoE facility models should include co-investment as a possibility, in addition to “pure” user or program facilities.

In addition to (and synergistic with) the development and growth of umbrella agreements, facility investment models, strategic alliances, and other alternative business models (as discussed above), it is recognized that there is great potential for removing impediments to other-agency investment in “traditional” WFO.

The actions below have high and immediate leverage and should be pursued by NNSA (or successor agency) as a priority as well. Recommended actions for the Deputy Administrator for Defense Programs and Associate Administrator for Management and Administration on WFO process improvements include:

- (1) *Eliminate need for Other Federal Agencies to certify to DoE/NNSA that they are following the law and Federal Acquisition Regulations (FAR)*: Engage with DoE counterpart to modify DoE Order 481.1C to eliminate this requirement from the Order.† If DoE does not concur, explore feasibility of NNSA unilateral direction to its Laboratories.
- (2) *WFO requirements for non-FFRDCs*: Engage with DoE counterpart to review the applicable laws, FAR, DoE Orders, and Department of Energy Acquisition Regulation (DEAR) clause to determine if DoE Order 481.1C and DEAR clause should be modified to reflect statutory requirements for non-FFRDC facilities’ WFO work.

* This variation would be a combination of the BOA approach and the IDIQ (indefinite delivery indefinite quantity) contracts that the DoD and other agencies use with great success.

† DoE Order 481.1 C, “Work For Others (Non-Department Of Energy Funded Work),” sets out basic guidelines for WFO.

- (3) *Delegate Interagency Acquisition approval to Laboratories:* Develop a pilot plan to allow for Laboratories to approve and execute Interagency Agreements. Decision to execute pilot will be based solely on NNSA Administrator approval of plan.
- (4) *WFO contract clauses should not be added that lead to additional oversight.*[‡]

Financial Management of WFO could be greatly improved by taking the following actions:

- (1) *Elimination of the Federal Administrative Charge:* Get congressional approval of a Blanket Pricing Exception for a 3% Federal Administration Charge (FAC) for all reimbursable work conducted at NNSA sites. If DoE does not concur, explore feasibility of NNSA unilateral direction to its Laboratories/Plants.[§]
- (2) *Alternative Approaches to 90-day advanced funding requirement for WFO Non-Federal Entities:* Pilot alternative approaches to 90-day advanced funding requirement for non-federal entity reimbursable projects to include:
 - i. Managing the 90-day advanced funding at the Budget and Reporting (B&R) level;
 - ii. Eliminating the 90-day advanced funding requirement and placing contractor escrow account at risk for any project that incurs a negative balance.
- (3) *Delegate funds certification and financial functions to Laboratories:* Develop a pilot plan with the Albuquerque Service Center, the appropriate site office, and Laboratory, delegating financial functions identified in the DoE Accounting Manual to the Laboratory. This would include the review of reimbursable agreements for adequacy and accuracy of relevant accounting and funding data, potential budgetary resource problems, pricing factors, and financial close-out procedures. In addition, the pilot program would delegate to an appropriate Laboratory the certifications of funds availability for reimbursable agreements. Decision to execution pilot will be based on NNSA Administrator approval of plan.

[‡] Numbers 3 and 4 in this list would automatically be addressed by the use of Basic Ordering Agreements outlined above.

[§] This exception is already applicable to the Department of Homeland Security and could be made universal to work at NNSA sites.

ENDNOTES

- ¹ Defense Science Board, "Report Summary," *Report of the Defense Science Board Task Force on Nuclear Capabilities* (Washington: Office of the Under Secretary of Defense for Acquisition, Technology, and Logistics, 2006): 23, accessed at: http://www.acq.osd.mil/dsb/reports/2006-12-Nuclear_Capabilities.pdf.
- ² National Academies Committee on Prospering in the Global Economy of the 21st Century: An Agenda for American Science and Technology and Committee on Science, Engineering, and Public Policy, *Rising Above the Gathering Storm* (Washington: National Academies Press, 2007).
- ³ Oxford Analytica, *National Innovation Systems of India and China* (January 12, 2009).
- ⁴ "Improvement" refers to the positive change within the GII index. The Human Capital portion of the GII Index is based upon a number of factors such as education expenditure as a percentage of the Gross National Income, literacy rate, quality of the educational system and quality of scientific research institutions. Soumitra Dutta et al., *Global Innovation Index 2008-2009* (Fontainebleau, France: INSEAD, 2009): 58, accessed at <http://www.insead.edu/facultyresearch/centres/elab/documents/GIIFinal0809.pdf>.
- ⁵ Thomas Friedman, *The World Is Flat: A Brief History of the Twenty-first Century* (New York: Farrar, Strauss and Giroux, 2005): 256.
- ⁶ John A. Gordon, "John A. Gordon Before the Senate Armed Services Committee," Testimony before Congress, Washington, DC (February 14, 2002), accessed at: <http://nnsa.energy.gov/news/958.htm>.
- ⁷ Defense Science Board, *Report of the Defense Science Board Task Force on Nuclear Deterrence Skills* (Washington: Office of the Under Secretary of Defense for Acquisition, Technology, and Logistics, 2008): 62-63, accessed at: <http://www.acq.osd.mil/dsb/reports/2008-09-NDS.pdf>.
- ⁸ National Academies, *Rising Above the Gathering Storm*, 209-210.
- ⁹ S. Mitra Kalita, "Hope and Toil at India's Call Centers," *The Washington Post* (December 27, 2005), accessed at: <http://www.washingtonpost.com/wp-dyn/content/article/2005/12/26/AR2005122600852.html>.
- ¹⁰ National Academies, *Rising Above the Gathering Storm*, 23.
- ¹¹ National Academies, *Rising Above the Gathering Storm*, 17.
- ¹² Friedman, *The World is Flat*, 268.
- ¹³ Information compiled from web sites and Task Force interviews/site visits with leadership from the following Laboratories: Argonne National Laboratory (October 7, 2008), Brookhaven National Laboratory, Idaho National Laboratory (November 7, 2008), Oak Ridge National Laboratory (October 22, 2008), Lawrence Livermore National Laboratory (September 26, 2008), Los Alamos National Laboratory (July 28, 2008), Pacific Northwest National Laboratory (October 7, 2008), and Sandia National Laboratories (July 29, 2008).
- ¹⁴ Ibid.
- ¹⁵ Dana A. Shea and Daniel Morgan, "The DHS Directorate of Science and Technology: Key Issues for Congress," CRS Report for Congress, RL34356 (June 9, 2008): 33, accessed at: http://assets.opencrs.com/rpts/RL34356_20080609.pdf.
- ¹⁶ David H. Crandall, *Overview: Work For Others (WFO) and Program Planning for Stimson Task Force*, presentation to the Stimson Center Task Force, Washington, DC (June 27, 2008).
- ¹⁷ Shea and Morgan, "The DHS Directorate of Science and Technology," 48.
- ¹⁸ John F. Sargent, Coordinator, "Federal Research and Development Funding: FY2009," CRS Report for Congress, RL34448 (October 23, 2008): 24, accessed at: http://assets.opencrs.com/rpts/RL34448_20081023.pdf.

- ¹⁹ National Academies, *Rising Above the Gathering Storm*, 93-94.
- ²⁰ Ibid, 156.
- ²¹ F.G. Gosling, *Manhattan Project: Making the Atomic Bomb* (Washington: Department of Energy, 1999): 5-7, 9, accessed at: <http://www.cfo.DoE.gov/me70/manhattan/publications/DE99001330.pdf>.
- ²² Ibid., 19.
- ²³ US Department of Energy Office of History & Heritage Resources, “Civilian Control of Atomic Energy (1945-1946),” *The Manhattan Project: An Interactive History*, accessed at: http://www.cfo.DoE.gov/me70/manhattan/civilian_control.htm.
- ²⁴ Ibid.
- ²⁵ Christopher M. Davis, “9/11 Commission Recommendations: Joint Committee on Atomic Energy — A Model for Congressional Oversight?” CRS Report for Congress, RL32538, (August 20, 2004): 2, accessed at: <http://www.fas.org/irp/crs/RL32538.pdf>.”
- ²⁶ Ibid., 2-3.
- ²⁷ Ibid., 14.
- ²⁸ Ibid., 15-21.
- ²⁹ Ibid., 22-23.
- ³⁰ US Department of State Office of the Historian, “Second Arab Oil Embargo, 1973-1974,” *Timeline of US Diplomatic History*, accessed at: <http://www.state.gov/r/pa/ho/time/dr/96057.htm>.
- ³¹ Ibid.
- ³² US Department of Energy, “Origins & Evolution of the Department of Energy,” *History* (March 26, 2008), accessed at: <http://www.energy.gov/about/origins.htm>.
- ³³ Special Investigative Panel, President’s Foreign Intelligence Advisory Board (hereinafter PFIAB), *Science At Its Best; Security At Its Worst: A Report on Security Problems at the US Department of Energy* (Washington: Executive Office of the President, 1999): I, accessed at: http://www.loyola.edu/dept/politics/intel/pfiab_DoE_report.pdf.
- ³⁴ Ibid., 9.
- ³⁵ Defense Science Board Permanent Task Force on Nuclear Weapons Surety, *Report on the Unauthorized Movement of Nuclear Weapons* (Washington: Office of the Under Secretary of Defense for Acquisition, Technology, and Logistics, 2008): 7, accessed at: http://www.cdi.org/pdfs/2008Nuclear_Weapons_Surety.pdf; James Schlesinger, “Quest for a Post-Cold War Foreign Policy,” *Foreign Affairs*, Vol. 72, Issue 1 (1993/1994): 17, accessed through JSTOR.
- ³⁶ Anne Fitzpatrick and Ivan Oelrich, *The Stockpile Stewardship Program: Fifteen Years On* (Washington: Federation of American Scientists, 2007): 12, accessed at: http://www.fas.org/2007/nuke/Stockpile_Stewardship_Paper.pdf .
- ³⁷ US Government Accountability Office, “Department of Energy: Plutonium Needs, Costs, and Management Programs,” GAO/RCED-97-98 (April 1997): 1, accessed at: <http://www.gao.gov/archive/1997/rc97098.pdf>; US Department of Energy, “Origins & Evolution of the Department of Energy.”
- ³⁸ National Nuclear Security Administration, *NNSA Strategic Planning Guidance for FY 2010 – FY 2014* (Washington: Department of Energy, 2008): 10.
- ³⁹ Secretary of Energy Advisory Board: Task Force on Alternative Futures for the Department of Energy National Laboratories, *Alternative Futures for the Department of Energy National Laboratories* (Washington: Department of Energy, 1995): 13, 23, 31, 40, 46, accessed at: <http://www.seab.energy.gov/sub/galvin/GAL-VOL1.pdf>.
- ⁴⁰ Commission on Maintaining United States Nuclear Weapons Expertise, *Report of the Commission on Maintaining United States Nuclear Weapons Expertise*, (Washington:

Commission on Maintaining United States Nuclear Weapons Expertise, 1999): 7, accessed at: <http://www.DoEal.gov/MOContracts/docs/ReadingRoom/ChilesReport.pdf>.

⁴¹ Ibid., 16-17.

⁴² Ibid., 23.

⁴³ Panel to Assess the Reliability, Safety, and Security of the United States Nuclear Stockpile (hereinafter The Foster Panel), *FY 1999 Report* (Washington: Panel to Assess the Reliability, Safety, and Security of the United States Nuclear Stockpile, 1999): 1-10, accessed at: <http://www.fas.org/nuke/guide/usa/doctrine/DoE/Fosterpa.pdf>.

⁴⁴ United States House of Representatives Select Committee on US National Security and Military/Commercial Concerns with the People's Republic of China, "Overview," *Final Report*, (Washington: US House of Representatives, 1999): ii, accessed at: <http://www.house.gov/coxreport/chapfs/over.html>.

⁴⁵ PFIAB, *Science At Its Best; Security At Its Worst*, 1.

⁴⁶ Ibid., 4-6.

⁴⁷ Ibid., 47-48.

⁴⁸ Ibid., 12.

⁴⁹ Ibid., 46.

⁵⁰ Ibid., 47.

⁵¹ Ellen Tauscher, "Opening Statement," presented at the House Armed Services Strategic Forces Subcommittee hearing regarding the Department of Energy's Progress Implementing the FY 2000 National Nuclear Administration Act, Washington, DC (January 31, 2007), accessed at: http://armedservices.house.gov/apps/list/speech/armedsvc_dem/tauscher_openingNNSA013107.shtml.

⁵² Government Printing Office, "Conference Report on S. 1059, National Defense Authorization Act for Fiscal Year 2000," *The Congressional Record* (September 15, 1999): H8311, accessed through Thomas.

⁵³ Government Printing Office, "National Defense Authorization Act for Fiscal Year 2000 – Conference Report," *The Congressional Record* (September 21, 1999): S11103, accessed through Thomas.

⁵⁴ National Nuclear Security Administration, *The National Nuclear Security Administration Act*, compilation of legislation, accessed at: http://www.nnsa.energy.gov/news/documents/NNSA_Act.pdf.

⁵⁵ The Foster Panel, *FY 2000 Report to Congress* (Washington: Washington: Panel to Assess the Reliability, Safety, and Security of the United States Nuclear Stockpile, 2001): 7, accessed at: <http://www.fas.org/nuke/control/ctbt/text/foster00.pdf>.

⁵⁶ Ibid., 24-25.

⁵⁷ John J. Hamre and Anne Witkowsky, *Science and Security in the 21st Century: A Report to the Secretary of Energy on the Department of Energy Laboratories* (Washington: Center for Strategic and International Studies, 2002). Quote taken from Synopsis on CSIS's publications page (http://www.csis.org/component?option=com_csis_pubs/task/view/id,29/).

⁵⁸ The Foster Panel, *FY 2001 Report to Congress* (Washington: Washington: Panel to Assess the Reliability, Safety, and Security of the United States Nuclear Stockpile, 2002): 10, 15, 19, 22, accessed at: <http://www.fas.org/programs/ssp/nukes/testing/fosterpnlrpt01.pdf>.

⁵⁹ Ibid., 19.

- ⁶⁰ The Foster Panel, *FY 2003 Report to Congress* (Washington: Washington: Panel to Assess the Reliability, Safety, and Security of the United States Nuclear Stockpile, 2003): ES-ii, accessed at: <http://www.fas.org/nuke/control/ctbt/text/foster03.pdf>.
- ⁶¹ Diana Heil, “Keeping Secrets Safe: Is NNSA Fulfilling Its Mission?” *Santa Fe New Mexican* (February 13, 2005), accessed through LexisNexis.
- ⁶² Tauscher, “Opening Statement,” hearing on NNSA implementation.
- ⁶³ *Ibid.*
- ⁶⁴ Defense Science Board, “Report Summary,” *Report of the Defense Science Board Task Force on Nuclear Capabilities*, 1.
- ⁶⁵ *Ibid.*, 15.
- ⁶⁶ *Ibid.*, 28.
- ⁶⁷ *Ibid.*, 23.
- ⁶⁸ Defense Science Board, *Report of the Defense Science Board Task Force on Nuclear Deterrence Skills*, 31, 37.
- ⁶⁹ Telephone interview with Sandia National Laboratories - California leadership on January 7, 2009.
- ⁷⁰ NNSA, *NNSA Strategic Planning Guidance for FY 2010 – FY 2014*, 10.
- ⁷¹ *Ibid.*
- ⁷² Defense Science Board, “Report Summary,” *Report of the Defense Science Board Task Force on Nuclear Capabilities* (Washington: Office of the Under Secretary of Defense for Acquisition, Technology, and Logistics, 2006): 23, accessed at: http://www.acq.osd.mil/dsb/reports/2006-12-Nuclear_Capabilities.pdf.
- ⁷³ Task Force on Alternative Futures, *Alternative Futures*, 54-56.
- ⁷⁴ *Ibid.*, 55.
- ⁷⁵ Defense Science Board, “Report Summary,” *Report of the Defense Science Board Task Force on Nuclear Capabilities*, 22.
- ⁷⁶ *Ibid.*, 27.
- ⁷⁷ Counterproliferation Program Review Committee, “Volume I – Executive Summary,” *Report on Activities and Programs for Countering Proliferation and NBC Terrorism*, (Washington: Department of Defense, 2006): 2, 15-16.
- ⁷⁸ Combating Terrorism Technology Support Office, *Combating Terrorism Technology Support Office 2007 Review* (Washington: Combating Terrorism Technology Support Office, 2008), accessed at: http://www.cttso.gov/reviewbook/2007_Review_PDF_Linked.pdf. See also: John K. Reingruber and Jeffrey M. David, “Technical Support Working Group,” Special Briefing on the Technical Support Working Group, Washington, DC (December 1, 2001), accessed at: <http://www.globalsecurity.org/military/library/news/2001/11/d20011129tswg.pdf>.
- ⁷⁹ US Department of Energy, “Work For Others (Non-Department Of Energy Funded Work),” DOE Order “DOE O 481.1C” (January 24, 2005), accessed at: <http://www.directives.DoE.gov/pdfs/DoE/DoEtext/neword/481/o4811c.html>.
- ⁸⁰ Oak Ridge National Laboratory. “US Department of Energy Research And Technical Assistant Program (Work for Others Program)” (October 13, 2008), accessed at: <http://www.ornl.gov/adm/wfo/exthome.htm>.
- ⁸¹ National Nuclear Security Administration, *Work with Others Concept: A Key to NNSA Complex Transformation through Partnerships for National Security* (Washington: Department of Energy, 2008): 8.
- ⁸² *Ibid.*, 5.

BIBLIOGRAPHY

- Argonne National Laboratory Nuclear Engineering Division. "National Security & Non-Proliferation Program" (March 14, 2008), accessed at: <http://www.ne.anl.gov/activ/programs/NSNP/>.
- Beason, J. Douglas. "Leveraging Los Alamos National Laboratory: A National Security Science Laboratory for the 21st Century," presentation to the Stimson Center Task Force, Washington, DC (June 27, 2008).
- Bothwell, Robert. "The Fuchs Case," *Science*, Vol. 238, No. 4828 (November 6, 1987): 831, accessed online through the publisher.
- Brookhaven National Laboratory. "History of the Nonproliferation and National Security Department" (February 11, 2009), accessed at: <http://www.bnl.gov/nns/>.
- BW Online Bureau. "India Not Among Top Innovators," *Businessworld* (January 6, 2009), accessed at: <http://www.businessworld.in/index.php/B-School/India-Not-Among-Top-Innovators.html>.
- Carter, Jimmy. "Department of Energy Organization Act and Bill Amending the Small Business Administration Act Remarks on Signing S. 826 and H.R. 692 Into Law" (August 4, 1977), quoted in: John Woolley and Gerhard Peters, *The American Presidency Project*, accessed at: <http://www.presidency.ucsb.edu/ws/index.php?pid=7916>.
- Combating Terrorism Technology Support Office. *Combating Terrorism Technology Support Office 2007 Review* (Washington: Combating Terrorism Technology Support Office, 2008), accessed at: http://www.cttso.gov/reviewbook/2007_Review_PDF_Linked.pdf.
- Commission on Maintaining United States Nuclear Weapons Expertise, *Report of the Commission on Maintaining United States Nuclear Weapons Expertise*, (Washington: Commission on Maintaining United States Nuclear Weapons Expertise, 1999), accessed at: <http://www.DoEal.gov/MOCContracts/docs/ReadingRoom/ChilesReport.pdf>.
- Commission on the Strategic Posture of the United States. "Interim Report," facilitated by the United States Institute of Peace (December 15, 2008), accessed at: http://www.usip.org/strategic_posture/sprc_interim_report.pdf.
- Counterproliferation Program Review Committee. "Volume I – Executive Summary," *Report on Activities and Programs for Countering Proliferation and NBC Terrorism*, (Washington: Department of Defense, 2006).
- Crandall, David H. *Overview: Work For Others (WFO) and Program Planning for Stimson Task Force*, presentation to the Stimson Center Task Force, Washington, DC (June 27, 2008).
- Davis, Christopher M. "9/11 Commission Recommendations: Joint Committee on Atomic Energy — A Model for Congressional Oversight?" CRS Report for Congress, RL32538, (August 20, 2004), accessed at: <http://www.fas.org/irp/crs/RL32538.pdf>.
- Defense Science Board. "Report Summary," *Report of the Defense Science Board Task Force on Nuclear Capabilities* (Washington: Office of the Under Secretary of Defense for Acquisition,

Technology, and Logistics, 2006), accessed at: http://www.acq.osd.mil/dsb/reports/2006-12-Nuclear_Capabilities.pdf.

———. *Report of the Defense Science Board Task Force on Nuclear Deterrence Skills* (Washington: Office of the Under Secretary of Defense for Acquisition, Technology, and Logistics, 2008), accessed at: <http://www.acq.osd.mil/dsb/reports/2008-09-NDS.pdf>.

Defense Science Board Permanent Task Force on Nuclear Weapons Surety. *Report on the Unauthorized Movement of Nuclear Weapons* (Washington: Office of the Under Secretary of Defense for Acquisition, Technology, and Logistics, 2008), accessed at: http://www.cdi.org/pdfs/2008Nuclear_Weapons_Surety.pdf.

Department of Energy. “Origins & Evolution of the Department of Energy.” *History* (March 26, 2008), accessed at: <http://www.energy.gov/about/origins.htm>.

———. “Pricing of Departmental Materials and Services,” DoE O 522.1 (November 3, 2004), accessed at: <http://www.directives.doe.gov/pdfs/doe/doetext/neword/522/o5221.pdf>.

———. “Work For Others (Non-Department Of Energy Funded Work),” DoE O 481.1C (January 24, 2005), accessed at: <http://www.directives.DoE.gov/pdfs/DoE/DoEtext/neword/481/o4811c.html>.

Department of Energy Office of History & Heritage Resources. “Civilian Control of Atomic Energy (1945-1946),” *The Manhattan Project: An Interactive History*, accessed at: http://www.cfo.DoE.gov/me70/manhattan/civilian_control.htm.

Department of State Office of the Historian. “Second Arab Oil Embargo, 1973-1974,” *Timeline of US Diplomatic History*, accessed at: <http://www.state.gov/r/pa/ho/time/dr/96057.htm>.

Dutta, Soumitra. “Technological Innovation in the Middle East,” INSEAD, accessed at: <http://knowledge.insead.edu/contents/Soumitra.cfm>.

Dutta, Soumitra, et al. *Global Innovation Index 2008-2009* (Fontainebleau, France: INSEAD, 2009), accessed at <http://www.insead.edu/facultyresearch/centres/elab/documents/GIIFinal0809.pdf>.

Fitzpatrick, Anne and Ivan Oelrich. *The Stockpile Stewardship Program: Fifteen Years On* (Washington: Federation of American Scientists, 2007), accessed at: http://www.fas.org/2007/nuke/Stockpile_Stewardship_Paper.pdf.

Friedman, Thomas. *The World Is Flat: A Brief History of the Twenty-first Century* (New York: Farrar, Strauss and Giroux, 2005).

Gordon, John A. “John A. Gordon Before the Senate Armed Services Committee,” Testimony before Congress, Washington, DC (February 14, 2002), accessed at: <http://nnsa.energy.gov/news/958.htm>.

Gosling, F.G. *Manhattan Project: Making the Atomic Bomb* (Washington: Department of Energy, 1999), accessed at: <http://www.cfo.DoE.gov/me70/manhattan/publications/DE99001330.pdf>.

- Government Accountability Office. "Department of Energy: Plutonium Needs, Costs, and Management Programs," GAO/RCED-97-98 (April 1997), accessed at: <http://www.gao.gov/archive/1997/rc97098.pdf>.
- . "Federal Research: Opportunities Exist to Improve the Management and Oversight of Federally Funded Research and Development Centers," GAO-09-15 (October 2008).
- Government Printing Office. "Conference Report on S. 1059, National Defense Authorization Act for Fiscal Year 2000," *The Congressional Record* (September 15, 1999), accessed through Thomas.
- . "National Defense Authorization Act for Fiscal Year 2000 – Conference Report," *The Congressional Record* (September 21, 1999), accessed through Thomas.
- . "National Defense Authorization Act for Fiscal Year 2000," *The Congressional Record* (May 27, 1999), accessed through Thomas.
- Hamre, John J. and Anne Witkowsky. *Science and Security in the 21st Century: A Report to the Secretary of Energy on the Department of Energy Laboratories* (Washington: Center for Strategic and International Studies, 2002).
- Heil, Diana. "Keeping Secrets Safe: Is NNSA Fulfilling Its Mission?" *Santa Fe New Mexican*, (February 13, 2005), accessed through LexisNexis.
- Idaho National Laboratory. "National Security" (January 24, 2007), accessed at: <http://www.inl.gov/nationalsecurity/>.
- Kalita, S. Mitra. "Hope and Toil at India's Call Centers," *The Washington Post* (December 27, 2005), accessed at: <http://www.washingtonpost.com/wp-dyn/content/article/2005/12/26/AR2005122600852.html>.
- Keese, David L. "Sandia National Labs Overview for National Security Laboratory Task Force, Henry L. Stimson Center," presentation to the Stimson Center Task Force, Washington, DC (June 27, 2008).
- Lawrence Livermore National Laboratory. "Mission, Vision and Values" (December 17, 2008), accessed at: <https://www.llnl.gov/llnl/about/missionvisionvalues.jsp>.
- . "Task Force – Leveraging National Laboratory S&T Assets for 21st Century Security," Background Material for the Henry L. Stimson Center (June 18, 2008).
- Los Alamos National Laboratory. "Global Reality, National Priority: History of National Security," accessed at: <http://www.lanl.gov/natlsecurity/index.shtml>.
- . "LANL Budget by Program Area" (June 2009).
- Miller, Byron S. "A Law is Passed—The Atomic Energy Act of 1946," *The University of Chicago Law Review*, Vol. 15, No. 4 (Summer 1948), accessed through JSTOR.
- Murray, Cherry A. "Lawrence Livermore National Laboratory: S&T Assets for the 21st Century," presentation to the Stimson Center Task Force, Washington, DC (June 27, 2008).

National Academies Committee on Prospering in the Global Economy of the 21st Century: An Agenda for American Science and Technology and Committee on Science, Engineering, and Public Policy. *Rising Above the Gathering Storm* (Washington: National Academies Press, 2007).

National Nuclear Security Administration. “NNSA Partners with DTRA on Key Nuclear Security Challenges” (December 17, 2008), accessed at: <http://nnsa.energy.gov/news/2254.htm>.

———. *Final Complex Transformation Supplemental Programmatic Environmental Impact Statement: Summary* (Washington: US Department of Energy, 2008).

———. *NNSA Strategic Planning Guidance for FY 2010 – FY 2014* (Washington: Department of Energy, 2008).

———. *The National Nuclear Security Administration Act*, compilation of legislation, accessed at: http://www.nnsa.energy.gov/news/documents/NNSA_Act.pdf.

———. *Work with Others Concept: A Key to NNSA Complex Transformation through Partnerships for National Security* (Washington: Department of Energy, 2008).

Oak Ridge National Laboratory. “National Security,” accessed at: http://www.ornl.gov/ornlhome/national_security.shtml.

———. “US Department of Energy Research And Technical Assistant Program (Work for Others Program)” (October 13, 2008), accessed at: <http://www.ornl.gov/adm/wfo/exthome.htm>.

Oxford Analytica. *National Innovation Systems of India and China* (January, 12 2009).

Pacific Northwest National Laboratory. “National Security Directorate” (February 2009), accessed at: <http://www.pnl.gov/nationalsecurity/>.

Panel to Assess the Reliability, Safety, and Security of the United States Nuclear Stockpile. *FY 1999 Report* (Washington: Panel to Assess the Reliability, Safety, and Security of the United States Nuclear Stockpile, 1999), accessed at: <http://www.fas.org/nuke/guide/usa/doctrine/DoE/Fosterpa.pdf>.

———. *FY 2000 Report to Congress* (Washington: Washington: Panel to Assess the Reliability, Safety, and Security of the United States Nuclear Stockpile, 2001), accessed at: <http://www.fas.org/nuke/control/ctbt/text/foster00.pdf>.

———. *FY 2001 Report to Congress* (Washington: Washington: Panel to Assess the Reliability, Safety, and Security of the United States Nuclear Stockpile, 2002), accessed at: <http://www.fas.org/programs/ssp/nukes/testing/fosterpnlrpt01.pdf>.

———. *FY 2003 Report to Congress* (Washington: Washington: Panel to Assess the Reliability, Safety, and Security of the United States Nuclear Stockpile, 2003), accessed at: <http://www.fas.org/nuke/control/ctbt/text/foster03.pdf>.

Reingruber, John K. and Jeffrey M. David. “Technical Support Working Group,” Special Briefing on the Technical Support Working Group, Washington, DC (December 1, 2001), accessed at: <http://www.globalsecurity.org/military/library/news/2001/11/d20011129tswg.pdf>.

- Sandia National Laboratories, "Military Programs," Labs Accomplishments (2008), accessed at: <http://www.sandia.gov/LabNews/labs-accomplish/2008/military.html>.
- . "Homeland Security & Defense" (January 29, 2009), accessed at: <http://www.sandia.gov/mission/homeland/index.html>.
- . "Institutional/Program Issues" (June 2009).
- Sargent, John F., coordinator. "Federal Research and Development Funding: FY2009," CRS Report for Congress, RL34448 (October 23, 2008), accessed at: http://assets.opencrs.com/rpts/RL34448_20081023.pdf.
- Schlesinger, James. "Quest for a Post-Cold War Foreign Policy," *Foreign Affairs*, Vol. 72, Issue 1 (1993/1994), accessed through JSTOR.
- Secretary of Energy Advisory Board: Task Force on Alternative Futures for the Department of Energy National Laboratories. *Alternative Futures for the Department of Energy National Laboratories* (Washington: Department of Energy, 1995), accessed at: <http://www.seab.energy.gov/sub/galvin/GAL-VOL1.pdf>.
- Shea, Dana A. and Daniel Morgan. "The DHS Directorate of Science and Technology: Key Issues for Congress," CRS Report for Congress, RL34356 (June 9, 2008), accessed at: http://assets.opencrs.com/rpts/RL34356_20080609.pdf.
- Special Investigative Panel, President's Foreign Intelligence Advisory Board (PFIAB), *Science At Its Best; Security At Its Worst: A Report on Security Problems at the US Department of Energy* (Washington: Executive Office of the President, 1999), accessed at: http://www.loyola.edu/dept/politics/intel/pfiab_DoE_report.pdf.
- Tauscher, Ellen. "Opening Statement," presented at the House Armed Services Strategic Forces Subcommittee hearing regarding the Department of Energy's Progress Implementing the FY 2000 National Nuclear Administration Act, Washington, DC (January 31, 2007), accessed at: http://armedservices.house.gov/apps/list/speech/armedsvc_dem/tauscher_openingNNSA013107.shtml.
- United States Congress. *The Atomic Energy Act of 1946*, Public Law 79-585, compiled by James D. Nuse, US Atomic Energy Commission (1965), accessed at: <http://www.osti.gov/atomicenergyact.pdf>.
- United States House of Representatives Select Committee on US National Security and Military/Commercial Concerns with the People's Republic of China. "Overview," *Final Report*, (Washington: US House of Representatives, 1999), accessed at: <http://www.house.gov/coxreport/chapfs/over.html>.
- Zook, Chris. *Beyond the Core: Expand Your Market Without Abandoning Your Roots* (Boston: Harvard Business School Press, 2004).

ABOUT THE STIMSON CENTER

Founded in 1989, The Henry L. Stimson Center is a nonprofit, nonpartisan institution devoted to enhancing international peace and security through a combination of rigorous analysis and results-oriented outreach on many of the most urgent national and international security challenges. Stimson focuses on three major priorities and areas of work:

- Strengthening institutions for international peace and security;
- Building regional security; and,
- Reducing weapons of mass destruction and transnational threats.

Stimson’s approach is pragmatic — geared toward providing policy alternatives, solving problems, and overcoming obstacles to a more peaceful and secure world. Through in-depth research and analysis, we aim to understand and illuminate complex issues. By engaging policymakers, policy implementers, and nongovernmental institutions, as well as other experts, we develop and propose recommendations that are nonpartisan, actionable, and effective.

ABOUT THE COOPERATIVE NONPROLIFERATION PROGRAM

The Cooperative Nonproliferation Program at the Stimson Center offers innovative, functional approaches to address the most significant threat to international security today: the spread of weapons of mass destruction. It seeks to bridge the gap between traditional “hard” security (proliferation) and “soft” security objectives (capacity-building, global development and public health). We partner with the public and private sector—an under-exploited resource—to achieve mutual security and development objectives. Only by exploring and leveraging all available means to address the growing threat of proliferation can we begin to treat its causes rather than its symptoms. For detailed information about our projects, please visit: <http://www.stimson.org/cnp>.